

Self & Dual Powered Overcurrent & Earth Fault Protection Relay



User Manual

MEVOCO
MEDIUM VOLTAGE COMPONENTS

Mevoco nv, Industrielaan 33A, 9800 Deinze, Belgium

+32 (0)9/380 30 49 • info@mevoco.be • www.mevoco.be

©2022 Mevoco nv

All rights reserved.

The information provided may not be reproduced and/or published in any way (electronically or mechanically) without the express prior written permission of Mevoco nv.

The information provided is subject to change insofar as it is based on general data regarding constructions, material properties and working methods known at the time of publication.

The information provided applies to the RP800 as a standard model. Mevoco nv cannot therefore be held liable for any damage resulting from specifications of the RP800 that deviate from the standard model.

The available information has been compiled with the greatest possible care. Mevoco nv does not accept responsibility for any errors that may occur in this document or for their possible consequences.

The general designations, trade names, brands, etc. used by Mevoco nv are protected by trademark law.

TABLE OF CONTENTS	2
1 RECEPTION, HANDLING & INSTALLATION	6
1.1 UNPACKING	6
1.2 RECEPTION OF RELAYS	6
1.3 HANDLING ELECTRONIC RELAY	6
1.4 INSTALLATION, COMMISSIONING AND SERVICE	7
1.5 STORAGE	7
1.6 RECYCLING	7
2 DIMENSIONS AND CONNECTION DIAGRAMS	1
2.1 FRONT VIEW	1
2.2 CASE DIMENSIONS	1
2.3 CONNECTION DIAGRAM	3
2.3.1 STANDARD CURRENT TRANSFORMERS	3
2.3.2 STANDARD CURRENT TRANSFORMERS	3
2.4 TERMINALS	4
3 DESCRIPTION	6
3.1 INTRODUCTION	6
3.2 RELAY DESCRIPTION	6
3.3 FUNCTIONAL DIAGRAM	9
3.4 FUNCTION SHB. SECOND HARMONIC BLOCKING	10
3.5 FUNCTION 50. INSTANTANEOUS PHASE OVERCURRENT	10
3.6 FUNCTION 51. INVERSE TIME PHASE OVERCURRENT	11
3.7 FUNCTION 50G. INSTANTANEOUS NEUTRAL OVERCURRENT	11
3.8 FUNCTION 51G. INVERSE TIME NEUTRAL OVERCURRENT	12
3.9 FUNCTION 49. THERMAL IMAGE PROTECTION	12
3.9.1 THERMAL IMAGE MEASUREMENT EVOLUTION GRAPHIC	13
3.9.2 THERMAL IMAGE WITH MEMORY	15
3.9.3 THERMAL IMAGE MEASUREMENT DISPLAY. RESET.	15
3.9.4 THERMAL PROTECTION CURVES	15
3.10 FUNCTION 52. CIRCUIT BREAKER MONITORING	16
3.11 CIRCUIT BREAKER OPENING AND CLOSING COMMANDS	19
3.12 COUNTER TO REGISTER THE NUMBER OF OPENINGS	19
3.13 ACCUMULATED AMPS COUNTER : I2T	19
3.14 MAXIMUM OPENINGS IN A TIME WINDOW	19
3.15 FUNCTION 49T. EXTERNAL TRIP	20
3.16 SETTINGS GROUPS	20
3.17 IEC60255-151 CURVES	20
3.18 IEEE CURVES	26
4 MONITORING AND CONTROL	30
4.1 MEASUREMENTS	30
4.2 LOAD DATA PROFILING	30
	3

4.3	COUNTERS	31
4.4	DEADBAND	31
4.5	STATES AND EVENTS	31
4.6	DATE AND TIME BY REAL TIME CLOCK (RTC)	35
4.7	SELF-DIAGNOSIS	35
4.8	DISTURBANCE FAULT RECORDING	37
4.9	CONFIGURABLE INPUTS	40
4.10	DIGITAL OUTPUTS	40
4.11	PROGRAMMABLE LOGIC CONTROL	40
4.11.1	OUTPUTS	41
4.11.2	LEDS	42
4.12	COMMANDS	45
4.13	TEST MENU	45
4.14	POWER SUPPLY	46
4.14.1	SELF-POWERED RELAY WITH STANDARD CURRENT TRANSFORMERS	46
4.14.2	24-230 VAC, 50/60 HZ AUXILIARY POWER	46
4.14.3	24-230 VDC AUXILIARY POWER SUPPLY	46
4.14.4	BATTERY POWER: 5 V, WITH A KITCOM ADAPTOR	47
4.14.5	COMMISSIONING BATTERY	47
4.15	SWITCH ON TO FAULT (SOTF) CHARACTERISTIC	51
4.16	OPENING MECHANISM: STRIKER	52

5 TECHNICAL SPECIFICATIONS AND STANDARDS **53**

5.1	TECHNICAL SPECIFICATIONS	53
5.2	THERMAL RESISTANCE	55

6 COMMUNICATION AND HMI **55**

6.1	FRONT COMMUNICATION: USB	55
6.2	REAR COMMUNICATION: RS485	55
6.3	LED INDICATORS	56
6.4	LCD AND KEYPAD	56
6.5	SICOM COMMUNICATIONS PROGRAM	57
6.5.1	HOW TO INSTALL THE SICOM SOFTWARE	57
6.6	SETTING-UP THE SESSION: PASSWORD AND ACCESS LEVELS	58
6.7	MENUS	59
6.7.1	STANDBY MODE SCREEN	59
6.7.2	ACCESSING THE MENUS	59
6.7.3	DATE-TIME MENU	59
6.7.4	VERSIONS	60
6.7.5	COMMUNICATION PARAMETERS	60
6.7.6	CONTRAST	60
6.7.7	FAULT REPORT	60
6.7.8	TESTMENU	61
6.7.9	FUNCTIONSMENU	62
6.7.10	MEASUREMENTS MENU	64
6.7.11	STATES MENU	65
6.7.12	SETTINGS MENU	74
6.7.13	EVENTS MENU	81

6.7.14	COUNTERS MENU	82
6.7.15	COMMANDS MENU	83
6.7.16	LOAD DATA PROFILING	84
6.7.17	FAULT REPORTS	84
6.7.18	PGC AND OUTPUTS CONFIGURATION MENU	85

7 COMMISSIONING **89**

7.1	CHECKLIST FOR COMMISSIONING	89
7.2	ELECTROSTATIC DISCHARGE	89
7.3	VISUAL INSPECTION	89
7.4	EARTHING	89
7.5	CURRENT TRANSFORMERS	89
7.6	AUXILIARY POWER	89
7.7	FRONT COMMUNICATIONS PORT	89
7.8	COMMISSIONING	89

8 APPENDIX **90**

8.1	IDENTIFICATION	90
8.2	CHECKS	90
8.3	TEST MENU	90
8.4	REGISTER OF COMMISSIONING SETTINGS	90
8.5	INPUTS	92
8.6	OUTPUTS	92
8.7	LEDS	92
8.8	COMMENTS	92

1 RECEPTION, HANDLING & INSTALLATION

1.1 Unpacking

Relays must only be handled by qualified personnel and special care must be taken to protect all of their parts from any damage while they are being unpacked and installed. The use of good illumination is recommended to facilitate the relay visual inspection.

The facility must be clean and dry, and relays should not be stored in places that are exposed to dust or humidity. Special care must be taken if construction work is taking place.

1.2 Reception of relays

It is necessary to inspect the relay at the time it is delivered to ensure that the relays have not been damaged during transport.

If any defect is found, the transport company and Mevoco should be informed immediately. If the relays are not for immediate use, they should be returned to their original packaging.

1.3 Handling electronic relay

Relays contain an electronic component that is sensitive to electrostatic discharges. Just by moving, a person can build up an electrostatic potential of several thousand volts. Discharging this energy into electronic components can cause serious damage to electronic circuits. It is possible that this damage may not be detected straight away, but the electronic circuit reliability and life will be reduced. This electronic component in the relay is well protected by the metal housing, which should not be removed as the relay cannot be adjusted internally.

If it is necessary to disassemble the electronic component, this must be carried out with care and contact with electronic components, printed circuits and connections must be avoided to prevent an electrostatic discharge that could damage one of the components. If the electronic components are stored outside the metal housing, they must be placed in an antistatic conductive bag.

If it is necessary to open a module, care must be taken to preserve the relay reliability and the duration of the life cycle as designed by the manufacturer by taking the following actions

- Touch the housing to ensure that you have the same potential
- Avoid touching the electronic components and handle the module by its edges.
- Remember that everyone who handles the module must have the same potential.
- Use a conductive bag to transport the module.

For more information about how to handle electronic circuits, consult official documents such as the IEC 147-OF

1.4 Installation, commissioning and service

The personnel in charge of installing, commissioning and maintaining this relay must be qualified and must be aware of the procedures for handling it. The product documentation should be read before installing, commissioning or carrying out maintenance work on the relay.

Personnel should take specific protection measures to avoid the risk of electronic discharge when access is unlocked on the rear part of the relay.

In order to guarantee safety, the crimp terminal and a suitable group tool must be used to meet isolation requirements on the terminal strip. Crimped terminations must be used for the voltage and current connections.

It is necessary to connect the relay to earth through the corresponding terminal, using the shortest possible cable. As well as guaranteeing safety for the personnel, this connection allows high frequency noise to be evacuated directly to earth.

The following checks must be performed before the relay is supplied:

- The rated voltage and polarity.
- The power rating of the CT circuit and the integrity of the connections.
- The integrity of the earth connection.

The relay must be used within the stipulated electrical and environmental limits.

Note: Regarding the current transformer circuits: Do not open a live CT secondary circuit. The high voltage produced as a result could damage the isolation and threaten lives.

1.5 Storage



If the relays are not going to be installed immediately, they must be stored in a dust- and humidity free environment after the visual inspection has been performed.

1.6 Recycling

Before recycling the relay, the capacitors should be discharged through the external terminals. All electrical power sources should be removed before performing this operation to avoid the risk of electrical discharge.

This product must be disposed of in a safe way. It should not be incinerated or brought into contact with water sources like rivers, lakes, etc.

Fanox Electronic, S.L. adheres itself to the 1st additional disposal of the Spanish 11/97 Standard in which it is said that the final user of the containers should give them, properly segregated by materials, to an authorized recovery, recycler or valuer company.

2 DIMENSIONS AND CONNECTION DIAGRAMS

2.1 Front view

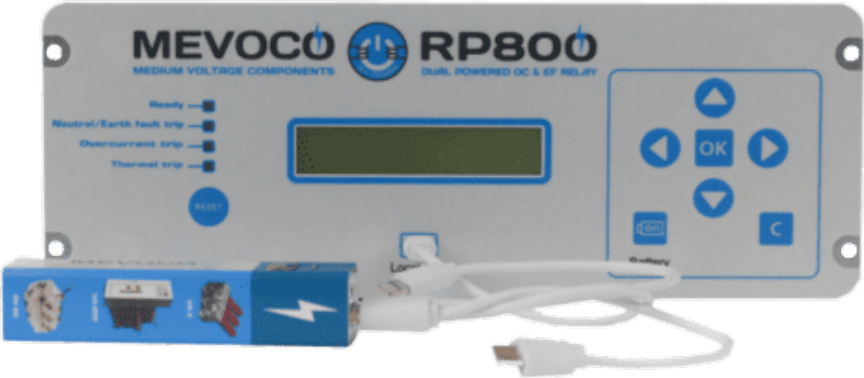

2.2 Case dimensions

The dimensions are in mm:

Option 1: Rear power terminals for 2.5 mm² cable:

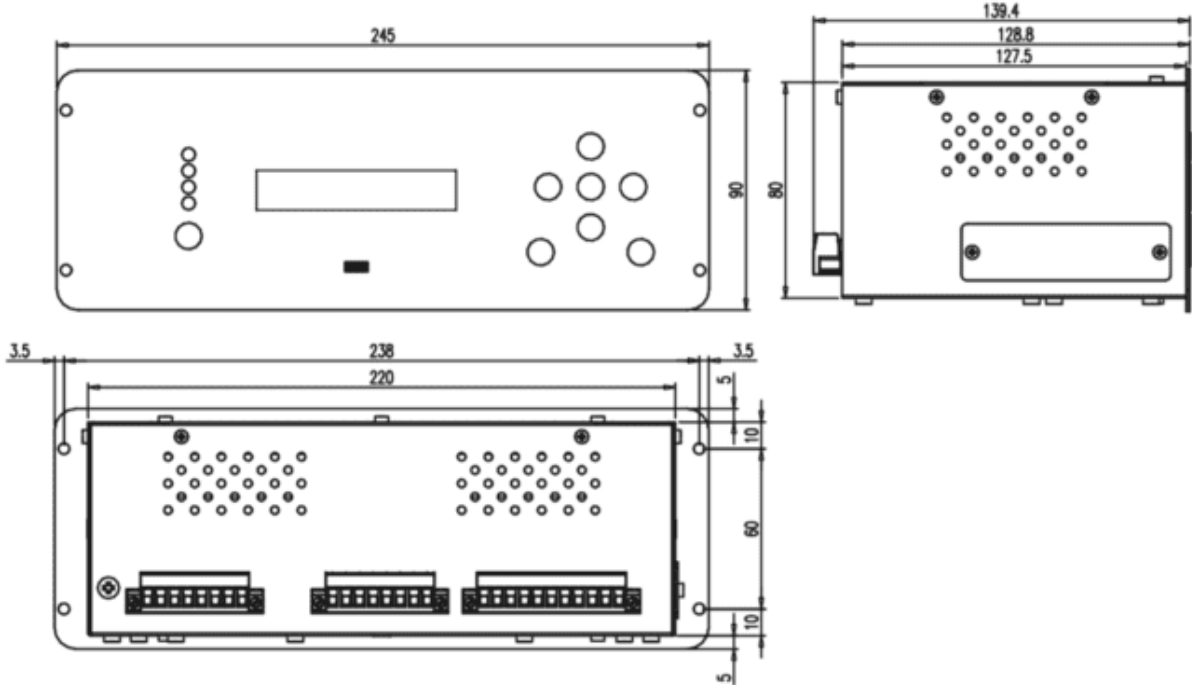

Option 2: Rear power supply terminals with ring terminals (cable 4 mm² – model RP800):

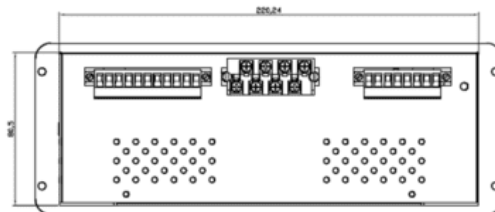
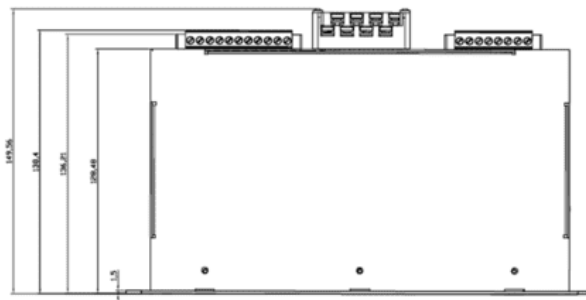
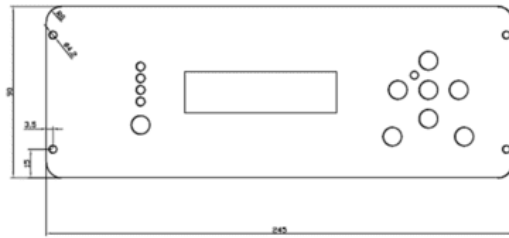

Cut-out pattern

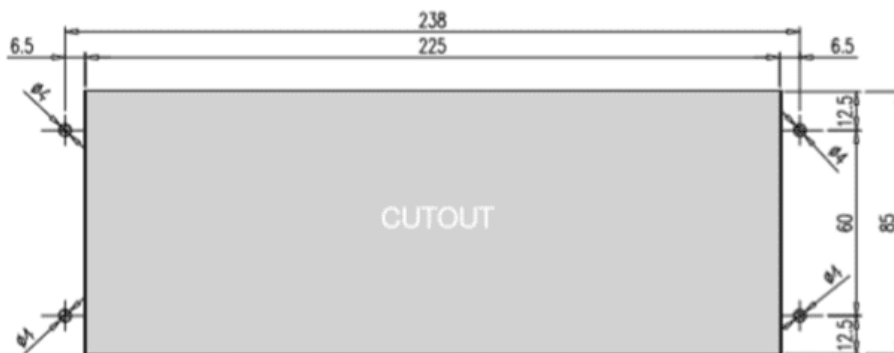

2.3 Connection diagram

2.3.1 Standard current transformers

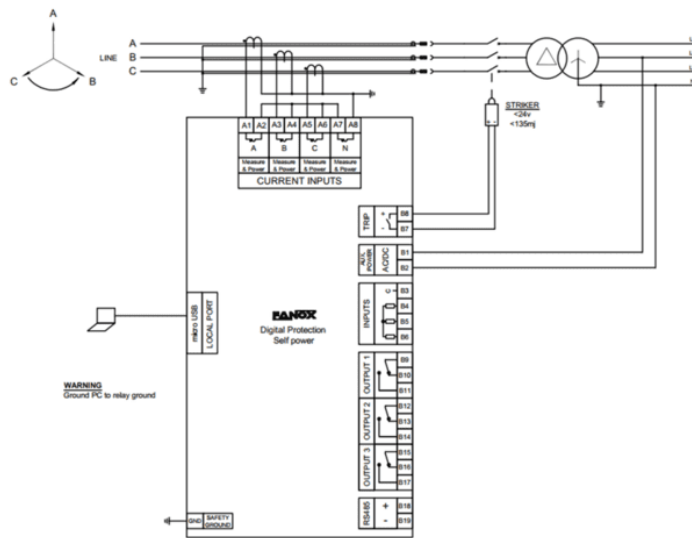

2.3.2 Standard current transformers

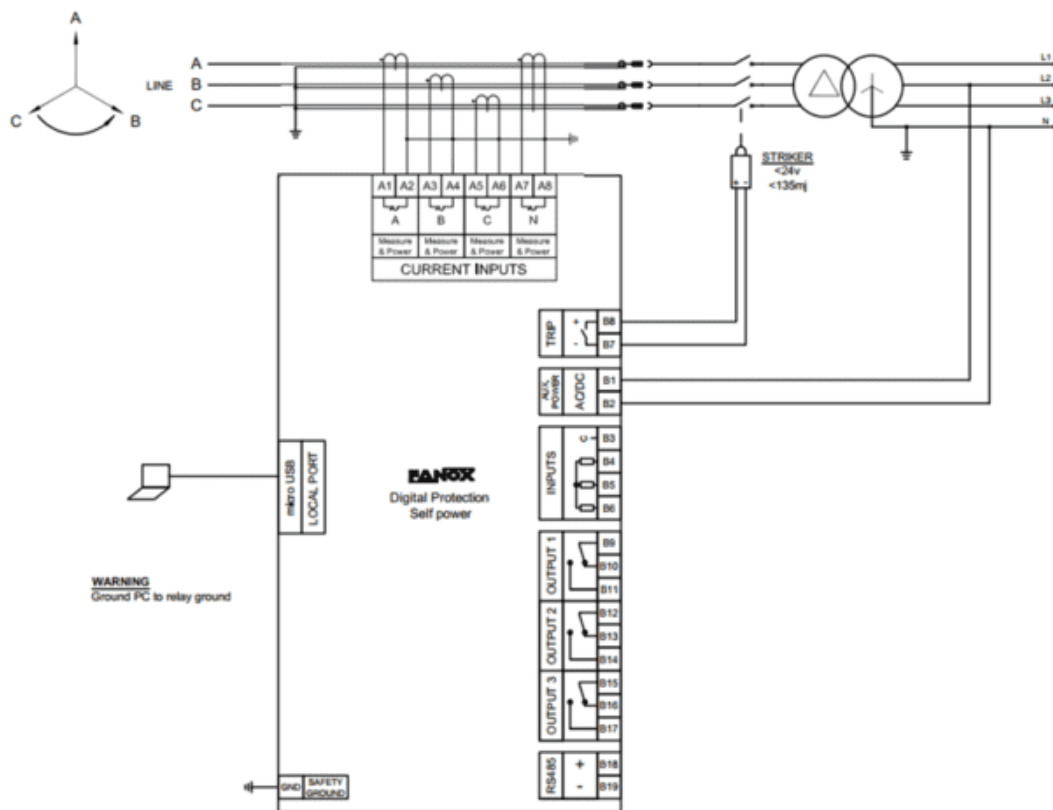

Note! trigger: 6 - 24 Vdc & ≤ 0.135 W.s

2.4 Terminals

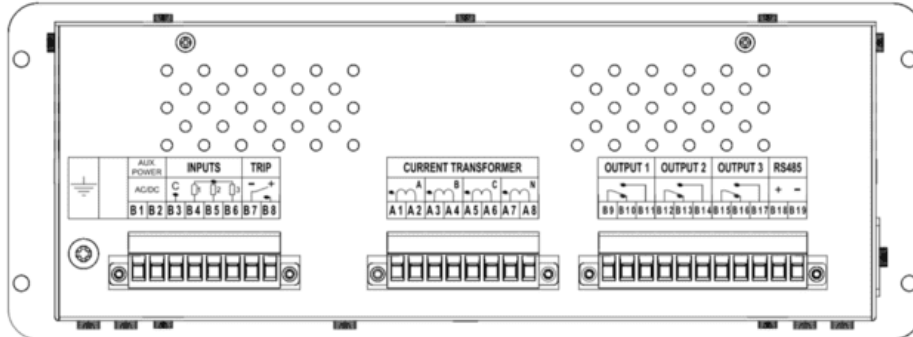

A1	Phase A current input for measurement and self-power
A2	Phase A current output for measurement and self-power
A3	Phase B current input for measurement and self-power
A4	Fase B stroomuitgang voor meting en eigen voeding.
A5	Phase C current input for measurement and self-power
A6	Phase C current output for measurement and self- power
A7	Neutral current input for measurement
A8	Neutral current output for measurement
B1	Auxiliary power supply +
B2	Auxiliary power supply -
B3	Common of the Inputs
B4	Input 1
B5	Input 2
B6	Input 3
B7	Trip output low energy trip coil+
B8	Trip output low energy trip coil -
B9	Digital 1 common output
B10	Digital output 1 NC
B11	Digitale output 1 NO
B12	Digital output 2 common output
B13	Digital output 2 NC
B14	Digital output 2 NO
B15	Digital output 3 commune
B16	Digital output 3 NC
B17	Digital output 3 NO
B18-B19	RS485 Remote communication

Use only copper conductors with a minimum temperature of 75°C.

There are 2 options for the current rear terminals:

Option 1: Rear terminals for 24 AWG - 12 AWG cable: 0.25 - 2.5 mm² with a torque of 0.5 Nm-0.6 Nm :

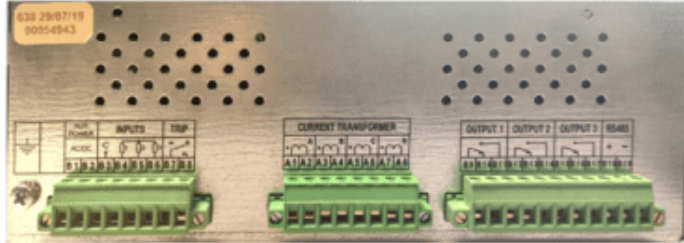
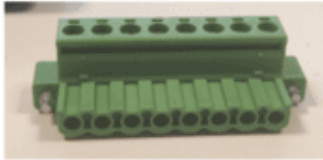

Option 2: Rear power supply terminals with ring clamps (12 AWG - 22 AWG: 4 - 0.3 mm² cable with torque of 0.79 Nm - Model SIABxxxxx7xx) :



The other terminals (inputs, outputs, communication and auxiliary power supply) are designed for 24 AWG - 12 AWG cable: 0.25 - 2.5 mm² with a tightening torque of 0.5 Nm-0.6 Nm.

3 DESCRIPTION

3.1 Introduction

Worldwide, the energy sector is currently undergoing a profound change as a result of high levels of energy demand; more distribution lines and advanced supervision systems are required. Given the need for creating intelligent infrastructure, Mevoco has developed the RP800 family of products to carry out this function.

The family of Mevoco relays is designed to protect the secondary transformation and distribution centers of electricity grids. Protection features include protection against instantaneous and inverse time overcurrent (for the phases and the neutral), and it also has external trip support (temperature, pressure, etc.) depending on the characteristics of each model.

The protection functions can be enabled selectively by using both the front panel and the communications links to the SICom program, allowing for precise coordination with another relay.

Additional benefits include that all of the models have been designed to be supplied from an external battery. This is aimed at facilitating event management and the commissioning of centers, as well as allowing it to operate properly under adverse conditions.

3.2 Relay description

The RP800 relay is a protection relay designed for secondary distribution. One of its main characteristics is the ability to power itself by using the cell current. Standard 1A secondary current transformers are used for this, which allow self-powering with lower levels of current.

The relay powers itself from 160 mA with single-phase current, 100 mA with 2-phase and 75 mA with three-phase current. It is important to consider that, despite of the device starts up with those values and trip output is activated in those values, to activate the optional outputs, it is needed a minimum of 270 mA single-phase current and a minimum of 90 mA three-phase current.

The relay is maintenance free when this type of power supply is used, as it does not require auxiliary power components (batteries). As a result, it is especially useful in any centers where auxiliary power is not available or cannot be guaranteed.

The RP800 relay is housed in a metal box with galvanic isolation on all its measurement inputs and outputs (except for communications ports and battery power supply, as these are sporadic connections). This fact allows the relay to have the best possible level of electromagnetic compatibility, both in terms of emission of, and immunity from, radiated and conducted interferences. These levels are the same as those established for primary substations.

The relay has an LCD with two lines and twenty columns and a membrane keyboard with six buttons. These allow the display of the relay state, the current measurements in the primary and the events or incidents associated with the relay, and adjustments to be made to the protection criteria.

There are four LED indicators on the front of the RP800 relay indicating the relay status and in case of fault trip the type of fault:

LEDS	DEFAULT CONFIGURATION
LED 1	Ready
LED 2	Neutral/Earth fault trip
LED 3	Overcurrent trip
LED 4	Thermal trip

Besides, the relay is provided with 3 signaling outputs that are also configurable by the user. By default:

Signaling outputs	DEFAULT CONFIGURATION
Output 1	Watchdog
Output 2	Phase Trip
Output 3	Ground trip

The RP800 relay has storage for up to 1024 events, allowing any registered incidents to be analyzed. RTC (Real Time Clock) is available for all RP800 models. To facilitate the analysis of events, it is fitted with 20 fault reports (16 events per fault report) and 10 records in COMTRADE format (50 cycles per record). Fault reports start when any of the protection functions picks-up and it finishes when any of the mentioned functions trips.

Current measurements are performed using RMS values. Standard current transformers (CTs) are used.

The relay has a frontal communication port (micro USB, cable not included). This port allows a PC to be connected, which can be used to monitor the relay using the SICom communications program. Besides, the frontal port can be used to power the relay by using an USB cable which can be directly connected with PC.

The protective functions provided, easy-to-use interface, low amount of maintenance and simple integration make the RP800 a precise and practical solution for protecting both industrial and public electrical grids and transformation and distribution centers. The main features of the relay are listed below, and these features will be explained in the rest of the manual:

Function	Description	RP-800
Protection		
50_1	Phase instantaneous overcurrent protection function	
50G_1	Ground nstantaneous overcurrent protection function	
50/51	Phase inverse time overcurrent protection function	
50/51G	Ground nstantaneous overcurrent protection function	
49T	External trip	
SHB	Second harmonic Blocking	
49	Thermal image	
PGC	Programmable Logic Control	
Circuit Breaker monitoring		
52	State and control of the circuit breaker	✓
	Number of openings counter	✓
	Accumulated amperes counter:	✓
	Maximum openings in a time window	✓
Measurements		
	Phase and neutral RMS measurement with $\pm 2\%$ over $\pm 20\%$ over the nominal current and $\pm 4\%$ of ± 5 mA in the rest of the range.	✓
Inputs and Outputs		
	External trip input (without power supply)	Via configureerbare ingangen
	Configurable inputs (without power supply)	3
	Trip output for STRIKER (135 mJ)	1
	Configurable signaling out (10A @ 30VDC-250)	3 (NO-NC)
Communication and IHM		
	Front port: micro USB (Modbus RTU)	✓
	Rear port: RS485 (Modbus RTU of DNP3.0 Serial)	✓
	SCom- Program	✓
	HMI: LCD, 20x2 and 6 keys + 1 reset button + 1 Battery key	✓
	LED -indicators	4
Power supply		
	Self-powering with standard CT's:	✓
	Auxiliary power : 24-230 Vdc / Vac, (50/60 Hz)	✓
	Internal comissioning battery	✓
Monitoring and recording		
	Events saved in the non-volatile FRAM* memory	1024
	Commands	✓
	Settings groups	4
	Real-Time Clock (RTC)	✓
	Disturbance Fault Recording (DFR)	20 fault (16 events each one) 10 record in COMTRADE format (50 cycles per record)
	Testmenu	✓
	Self-diagnosis	✓

- Events registered in the FRAM are maintained when there is a power fault, as it is a non-volatile memory. A maximum of 1024 events can be stored.
- Fault reports registered in the FRAM are maintained when there is a power fault, as it is a non-volatile memory. A maximum of 20 fault reports and 10 records in COMTRADE format can be stored.

3.3 Functional Diagram

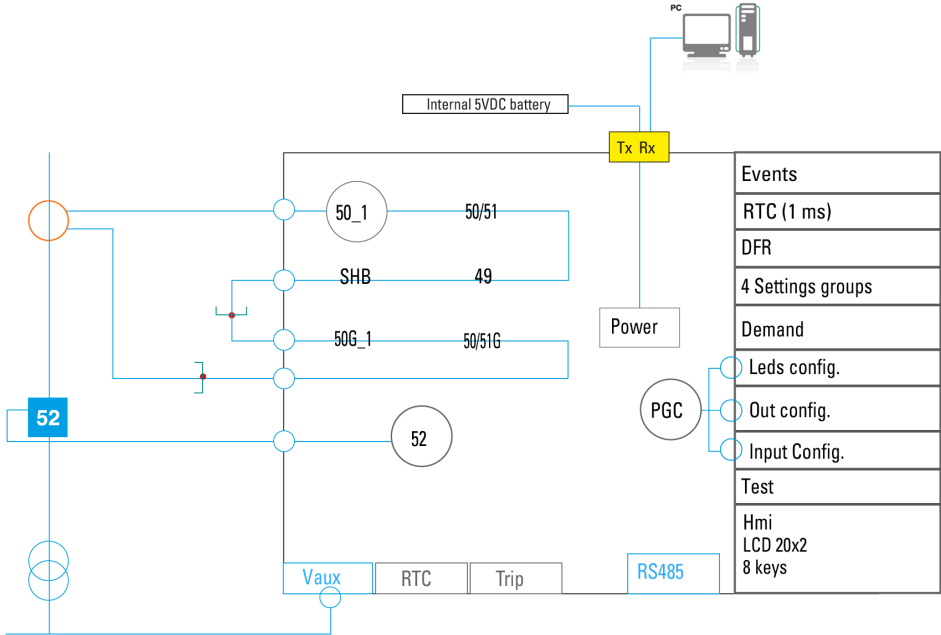

3.4 Function SHB. Second Harmonic Blocking

The second harmonic blocking is used to avoid an undesirable behavior due to inrush current when energizing a machine like a transformer or a generator.

Group	Description	Minimum	Maximum	Step	Unit	Default
SHB	Second harmonic blocking					
	Function Enable	-	-	Yes/No	-	No
	Current tap	5	50	1	%	5
	Reset time	0.00	300.00	0.01	s	0.00
	Block Threshold	0.07	20.0	0.01	xIn	10

In order to avoid these undesirable trips, if the second harmonic percentage is higher than the pre-set value, the trip will be blocked during the time set in reset time parameter.

The function picks-up at 100% off the adjusted input and the dropout is at 95%. The reset type will depend on the adjusted reset time.

The SHB will only be applied in functions that have this option in the “function enable” setting”. When the Function Enable of these protection functions is set to “SHB”, the relay will supervise the second harmonic content in order to trip or block the trip depending on the percentage of second harmonic present in the current signal.

The block threshold is activated at 100% and deactivated at 95% of its value.

3.5 Function 50. Instantaneous phase overcurrent

This protection function can be set by using three parameters:

Function	Description	Minimum	Maximum	Step	Unit
50_1	Instantaneous phase overcurrent				
	Function Enable	-	-	Yes/No/SHB	-
	Current Tap	0.2	20.00	0.01	xIn
	Time Delay	0.02	3	0.01	s

The Time Delay is independent from the operating current flowing through the relay, so if the phase current exceeds its predetermined value for an equal or greater amount of time than this pre-set value, the protection function activates (trips) and does not reset itself until the value of the phase drops below the point of current tap.

When the Function Enable is set to “YES”; the accuracy of the Time Delay is equal to the pre-set time ± 30 ms or $\pm 0.5\%$ (whichever is greater). If the Function Enable is set to “SHB”, the accuracy of the Time Delay is equal to the pre-set time ± 50 ms or $\pm 0.5\%$ (whichever is greater).

The function activates at 100% of the pre-set input and deactivates at 95%. The reset is instantaneous

3.6 Function 51. Inverse time phase overcurrent

This protection function can be set by using five parameters:

Function	Description	Minimum	Maximum	Step	Unit
51	Inverse time phase overcurrent				
	Function Enable	-	-	Ja/Nee/SHB	-
	Curve type	-	-	(1*)	
	Time Dial (TMS)	0,01	1,5	0,01	
	Current Tap	0,2	7,00	0,01	xIn
	Time Delay	0,02	3	0,01	s

(1*) IEC Inverse, IEC Very inverse, IEC Extremely inverse, IEC Long time inverse, Defined time, IEEE Inverse, IEEE Very inverse, IEEE Extremely inverse.

If the option “Defined time” is selected for the curve setting, the unit behaves like an instantaneous overcurrent unit. In this case, when the Function Enable is set to “YES”; the accuracy of the Time Delay is equal to the pre-set time ± 30 ms or $\pm 0.5\%$ (whichever is greater). If the Function Enable is set to “SHB”, the accuracy of the Time Delay is equal to the pre-set time ± 50 ms or $\pm 0.5\%$ (whichever is greater). In this case, the function is activated at 100% of the set tap value, and it deactivates at 95%. If a curve (inverse, very inverse or extremely inverse) is selected for the curve setting, the trip time depends on the curve, time dial and current tap settings. When the Function Enable is set to “YES”; the accuracy of the trip time is equal to the theoretical trip time ± 30 ms or $\pm 5\%$ (whichever is greater). If the Function Enable is set to “SHB”, the accuracy of the trip time is equal to the theoretical trip time ± 50 ms or $\pm 5\%$ (whichever is greater). In this case, the function is activated at 110% of the set tap value, and it deactivates at 100%. Instantaneous reset in both cases. The curves used are IEC 60255-151 and IEEE, which are described in their section.

3.7 Function 50G. Instantaneous neutral overcurrent

This protection function can be set by using three parameters:

Function	Description	Minimum	Maximum	Step	Unit
50G_1	Instantaneous neutral overcurrent				
	Function enable	-	-	Ja/Nee/SHB	-
	Current Tap	0,2	10,00	0,01	xIn
	Time Delay	0,02	2	0,01	s

The Time Delay is completely independent from the operating current that flows through the relay, so if the neutral current exceeds its predetermined value for an equal or greater amount of time than this pre- set value, the protection function

activates (trips) and does not reset itself until the value of the phase drops below the point of current pick-up.

When the Function Enable is set to “YES”; the accuracy of the Time Delay is equal to the pre-set time

± 30 ms or $\pm 0.5\%$ (whichever is greater). If the Function Enable is set to “SHB”, the accuracy of the Time Delay is equal to the pre-set time ± 50 ms or $\pm 0.5\%$ (whichever is greater).

The function activates at 100% of the pre-set input and deactivates at 90%. The reset is instantaneous.

3.8 Function 51G. Inverse time neutral overcurrent

This protection function can be set by using the following parameters:

Function	Description	Minimum	Maximum	Step	Eenheid
51	Inverse time neutral overcurrent				
	Funcie Enable	-	-	Ja/Nee/SHB	-
	Curve type	-	-	(1*)	
	Time Dial (TMS)	0,01	1,5	0,01	
	Current Tap	0,2	7,00	0,01	xIn
	Time Delay	0,02	2	0,01	s

(1*) IEC Inverse, IEC Very Inverse, IEC Extremely Inverse, IEC Long Time Inverse, Defined Time, IEEE Inverse, IEEE Very Inverse, IEEE Extremely Inverse

If the option “Defined time” is selected for the curve setting, the unit behaves like an instantaneous overcurrent unit. In this case, when the Function Enable is set to “YES”; the accuracy of the Time Delay is equal to the pre-set time ± 30 ms or $\pm 0.5\%$ (whichever is greater). If the Function Enable is set to “SHB”, the accuracy of the Time Delay is equal to the pre-set time ± 50 ms or $\pm 0.5\%$ (whichever is greater). In this case, the function is activated at 100% of the set tap value, and it deactivates at 95%.

If a curve (inverse, very inverse or extremely inverse) is selected for the curve setting, the trip time depends on the curve, time dial and current tap settings. When the Function Enable is set to “YES”; the accuracy of the trip time is equal to the theoretical trip time ± 30 ms or $\pm 5\%$ (whichever is greater). If the Function Enable is set to “SHB”, the accuracy of the trip time is equal to the theoretical trip time ± 50 ms or $\pm 5\%$ (whichever is greater). In this case, the function is activated at 110% of the set tap value, and it deactivates at 100%.

Instantaneous reset in both cases.

The curves used are IEC 60255-151 and IEEE,

3.9 Function 49. Thermal Image Protection

Thermal image is a measure of heating and cooling of an electric machine. Unlike overcurrent protection, it does not start counting the time when it detects a fault, but it is continuously determining the thermal state of the machine that monitors. The trip

time depends on the thermal constants adjusted, the current flowing and the prior thermal state of the machine.

The thermal image is calculated based on the following equation:

$$\theta = 100 \times (I/I_t)^2 \times (1 - e^{-t/\zeta}) + \theta'0 \times e^{-t/\zeta}$$

Where :

- I, maximum R.M.S.-current of three phases
- I_t, adjusted tap current
- ζ, thermal constant
- θ'0, initial thermal state

The trip time is given by the equation:

$$t = \zeta \times \ln \times \{[(I/I_t)^2 - (\theta'0 / 100)] / [(I/I_t)^2 - 1]\}$$

The algorithm uses the maximum of the three phase currents. If the maximum is greater than 15% of the adjusted tap, heating thermal constant is applied. If the maximum is less than 15% of the adjusted tap cooling thermal constant is considered.

The overload function trips when the thermal image reaches the value of 100%. This value is reached in time when the current is equal to the function adjusted in thermal function.

It provides an adjustable level of thermal imaging to generate an alarm. If the trip occurs, the function is reset when the thermal image falls below the set alarm level. As the current measurement algorithm used is R.M.S., in the thermal model is considered the heat produced by the harmonics.

This protection function is adjusted by setting five different parameters:

Function	Description	Minimum	Maximum	Pitch	Default	Defect
49	Thermal image protection function					
	Function Enable	-	-	Yes/No	-	No
	Current Tap	0,10	2,40	0,01	x In	1,2
	ζ heating	3	600	1	min	3
	ζ cooling	1	6	1	ζ heating	1
Alarm	20	99	1	%	80	

3.9.1 Thermal image measurement evolution graphic

On next graphic, thermal image measurement evolution can be observed depending on applied current:

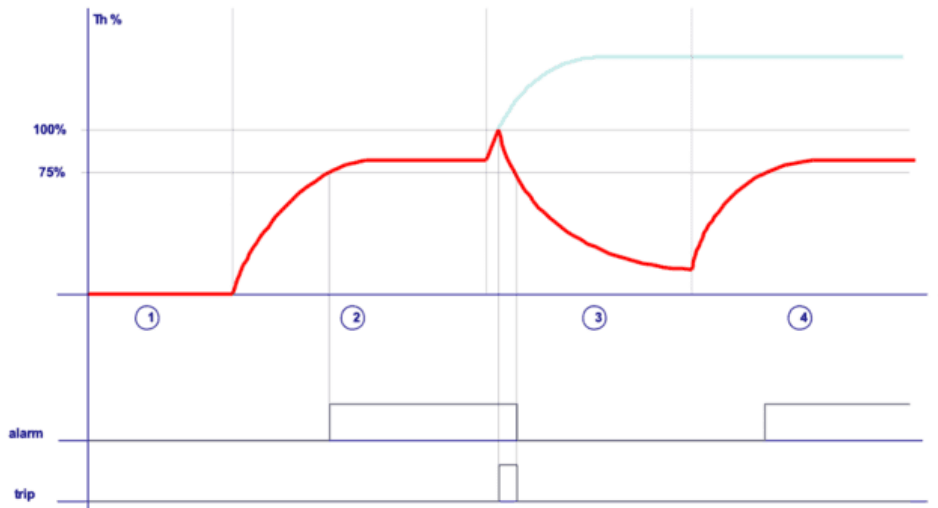

Supposing that thermal image protection has an adjusted tap of 1,1 times the nominal current and an alarm level of 75%:

- Zone 1: The machine is de-energized for a long time. Thermal image is 0%.
- Zone 2: The machine is supplied with the nominal current. Thermal image evolves so as to get the value of the thermal balance corresponding to one time the nominal current $Th = (I/I_t)^2$
= 82%. The time that it takes in getting the thermal balance depends on the adjusted heating constant.
- Zone 3: Once reached the thermal image corresponding to the application of one time the nominal current, it is applied 1,2 times the nominal current. Thermal image would evolve so as to get the thermal balance corresponding to 1,2 times the nominal current $Th = (I/I_t)^2 = 119\%$. This would occur if the Function Enable of the thermal function is disabled. If the Function Enable is disabled, 49 protection function performs when the thermal image reaches the value of 100%. Once tripped, current is cut and thermal image is getting cool based on the cooling constant.
- Zone 4: Before getting totally cool, nominal current is applied again and thermal balance is reached once passed the time determined by the heating thermal constant.

The accuracy of the trip time is the theoretical trip time is $\pm 5\%$ of the theoretical time.

Thermal image protection alarm bit is active if the thermal image measurement is over the adjusted alarm level and it is reset when the thermal image value is below the 95% of the set alarm.

Thermal image protection trip bit is active when the measurement of the thermal image is over 100%. and it is reset when the measurement of the thermal image is under 100%.

3.9.2 Thermal image with memory

Thermal image is stored in non-volatile RAM memory periodically. By this way, though the relay loses the power supply, it will keep the thermal state of the machine.

3.9.3 Thermal image measurement display. Reset.

Thermal image measurement can be displayed on Measurement menu.

3.9.4 Thermal protection curves

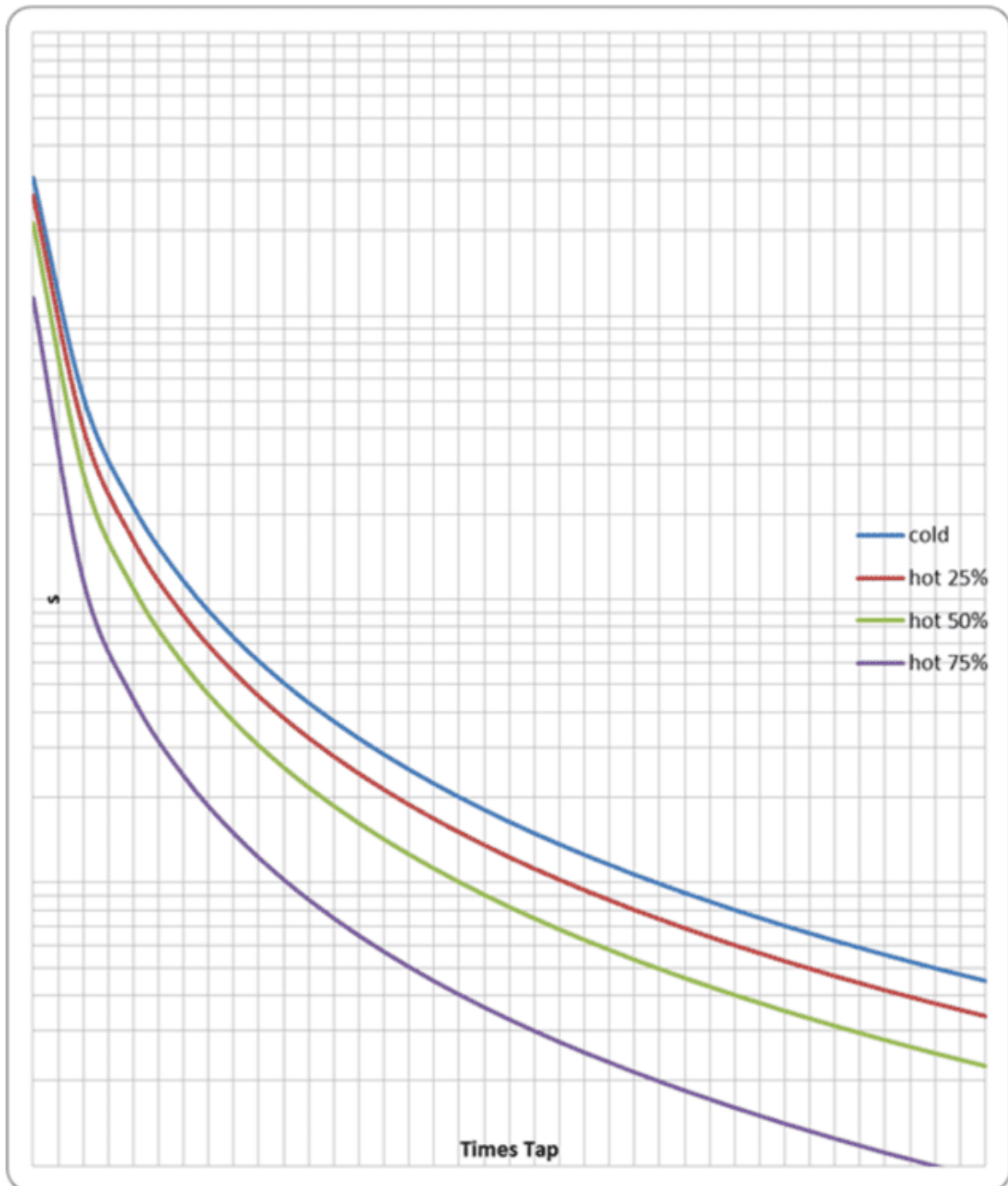

This is the thermal curve for $\zeta = 3$ minutes.

3.10 Function 52. Circuit Breaker monitoring

This function allows the status of the circuit breaker to be monitored and preventive maintenance to be performed, for which the following parameters need to be configured:

Group	Description	Minimum	Maximum	Step	Unit
52	Circuit breaker monitoring				
	Maximum number of openings	1	10,00	1	-
	Maximum accumulated amperes	1	100,00	1	M(A ²)
	Opening time	0,02	30,00	0,01	s
	Closing time	0,02	30,00	0,01	s
	Maximum repeated openings	1	10,000	1	-
	Time of maximum repeated openings	1	300	1	min

NOTE: The “Maximum accumulated amperes” adjustment units are M(A²) (square mega amperes) whilst the “Accumulated amperes counter” units are K(A²) (square kilo amperes).

It is also necessary to assign the logical inputs 52a and/or 52b to a physical input. This function provides information about the circuit breaker status and if any maintenance alarm has been activated.

The following statuses are associated with this function:

Function	Status	Description
52	Start	Energized/Deenergized
	Error	
	Open	
	Opening time	
	Opening error	
	Closed	
	Closing time	
	Closing error	
	Number of configured openings exceeded	Activated if the counter that measures the number of openings exceeds the “Maximum number of openings” setting
	Number of configured accumulated (I ² t) amps exceeded	Activated if the accumulated amps counter exceeds “Maximum accumulated amps” setting
Repeated Trips	Activated the number of openings exceeds the setting in “Maximum repeated openings” for the	

		time set in "Time of maximum repeated openings"
--	--	---

The way that the circuit breaker is monitored becomes more or less complex depending on whether it is fitted with no breaker contacts, one breaker contact (52a or 52b) or both (52a and 52b).

If no breaker contacts are used, the monitoring of the circuit breaker is made through the current measurement. This is, if less than 60 mA is detected it is considered the breaker is open and for higher currents the CB is considered closed.

If only the circuit breaker 52a contact is available, it should be wired to the corresponding physical input. This physical input is then assigned to the "52a" logic signal. The 52b logic signal is calculated internally as the negative of 52a.

If only the circuit breaker 52b contact is available, it should be wired to the corresponding physical input. This physical input is then assigned to the "52b" logic signal. The 52a logic signal is calculated internally as the negative of 52b.

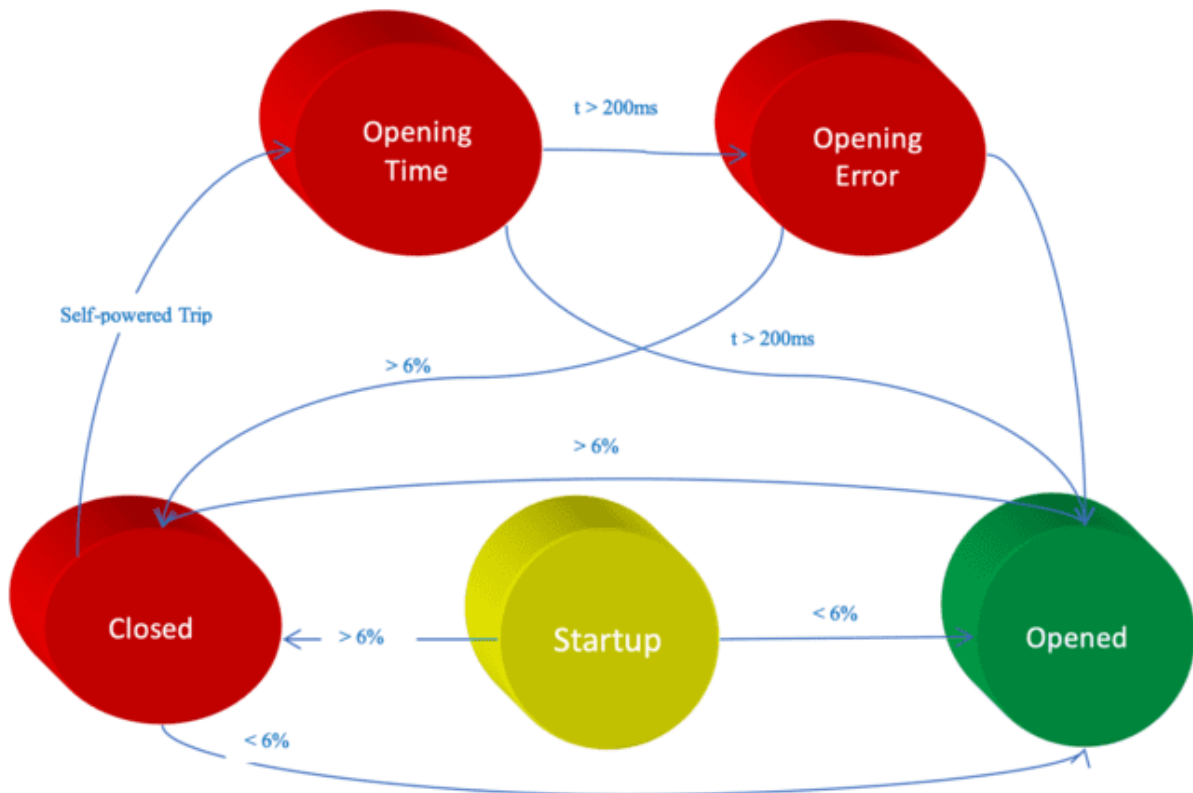

If both of the circuit breaker contacts 52a and 52b are available, they should be wired to the two physical inputs. These physical inputs are then assigned to the corresponding logic signals: the circuit breaker 52a contact to the "52a" logic signal, and the circuit breaker 52b contact to the "52b" logic signal. The circuit breakers automaton is considered as having eight statuses: Start, open, closed, error, opening time, opening error, closing time and closing error.

The circuit breaker performance is shown in the following finite state machine:

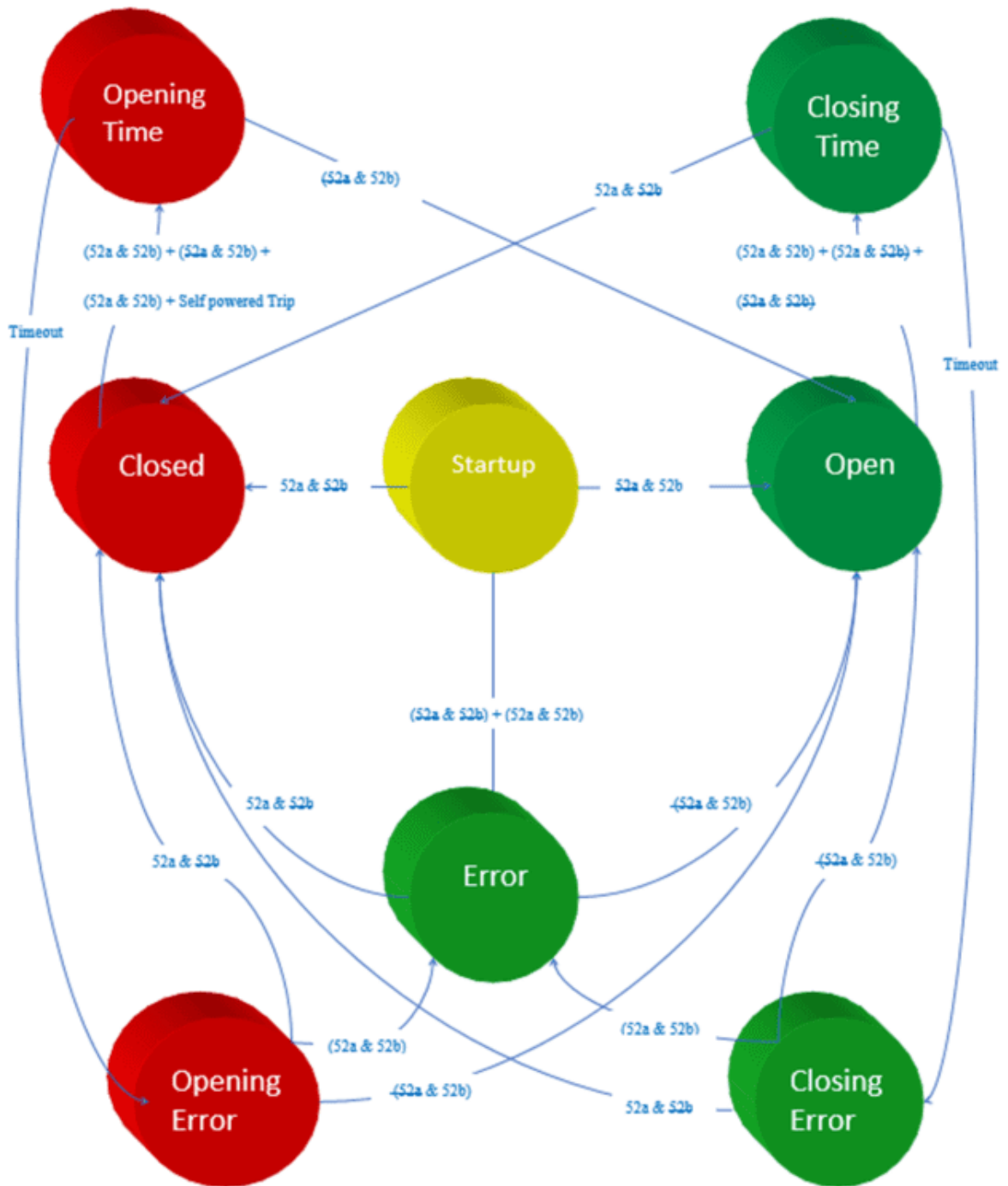

3.11 Circuit Breaker opening and closing commands

The circuit breaker opening and closing commands are implemented. These commands can be executed from the HMI commands menu or using the HMI's specific keypad or from local or remote communications. In order that the command related to the key can run, the menu must be in standby mode.

To carry out commands from the remote communications (ModBus, IEC60870-5-103, IEC61850 or DNP 3.0) the relay must be in TELECONTROL mode. (see the telecontrol section).

For the commands to have an effect, they should be assigned to the corresponding outputs. The "Open circuit breaker" and "Close circuit breaker" bits are assigned to their corresponding outputs in the "CONTROL" status group in the status menu.

3.12 Counter to register the number of openings

The SIA-B relay is fitted with a counter that registers the number of times the circuit breaker opens. This counter is associated with the "Maximum number of openings" setting. When the number of openings exceeds this preset value, the "Maximum number of openings" status is activated, and its corresponding event is generated.

This counter reading can be set to any value from within its range from the HMI or by communications.

3.13 Accumulated amps counter : I2t

An accumulated amps counter is also fitted. This counter accumulates the amps that are cleared by the circuit breaker by opening.

When the circuit breaker opens, the maximum number of primary amps in any of the phases is detected. This reading is squared and divided by 1000 and then rescaled to KA and accumulated. If the current detected in the opening is less than the rated current, the rated current value is used for the accumulation.

It is used in conjunction with the counter of the number of openings, to measure the circuit breaker aging process.

Since primary amps are being accumulated, it is essential to correctly adjust the phase CT transformation ratio.

The "Maximum accumulated amps" setting is associated with this counter. When the number of accumulated amps exceeds this preset value, the "Maximum accumulated amps" status is activated and its corresponding event is generated.

The value of this counter can be started at any value within its range from the hmi or from communications, if this protection is fitted on a circuit breaker with a previous service life.

This alarm can be replaced by modifying the Accumulated Amps counter. The display unit shall be KA^2 (square kilo amperes).

3.14 Maximum openings in a time window

As well as counting the number of times the circuit breaker opens, the SIA-B relay sets up a time window and the maximum number of openings allowed during this time. Both parameters can be adjusted.

When this number is exceeded, the "Repeated Trips" status is activated and its corresponding event is generated.

This alarm resets itself, when the corresponding time is exceeded with less trips than those indicated.

3.15 Function 49T. External trip

The relay has 3 configurable inputs and any of them can be configured as external trip input (by default input 1 is configured as external trip input). All three inputs are normally connected to a bimetallic contact fitted to the power transformer. This serves as a backup to the overcurrent functions.

Auxiliary supply is not required. It allows the connection of a bimetallic free potential contact. When this contact closes, it activates the input.

This input is especially protected against magnetic noise.

The external trip is available from the minimum required current to power the relay. In order to utilize this functionality, the circuit breaker must be equipped with a low energy coil!

3.16 Settings groups

There are four settings Setting groups and one general Setting group. The settings Setting group which is active at a specific moment can be modified in two ways:

- Changing the active Setting group settings. In the general group there is a setting which establishes which Setting group is active (Setting group 1, Setting group 2, Setting group 3 or Setting group 4).
- By means of two inputs. To this end four possibilities are defined.

00	This situation is governed by the active Setting group settings.
01	Setting group 1
10	Setting group 2
11	Setting group 3

Setting group 4 is not possible to be selected through inputs, only through general settings.



NOTE: Settings groups general setting should be different to the set in CLP function. If they are equal, the relay will work with Setting group 1. In the zero position the active item is defined by the active Setting group settings defined in the general group. Regarding other options, regardless of that established by the settings, the inputs prevail over the settings.

If the use of both inputs is not required, then one can be used, but depending on which is used, operation can be done with Setting group 1 or Setting group 2.

3.17 IEC60255-151 Curves

The SIA-B relay complies with the curves shown in standard IEC60255-151:

- Inverse Curve
- Very Inverse Curve

- Extremely Inverse Curve
- Long time inverse

There is a general mathematical equation that defines the time in seconds as a function of the current:

$$t = \frac{A \times D}{V^P - Q} + B \times D + K \qquad V = \frac{I}{I_{adjusted}}$$

Parameters	A	P	Q	B	K
Long Time Inverse	120	1	1	0	0
Ext. Inverse	80	2	1	0	0
Very Inverse	13,5	1	1	0	0
Inverse	0,14	0,02	1	0	0

The curve can mode from its axis using the D time selection device, which the user can adjust. Iadjusted is the initial operating current, set by the user.

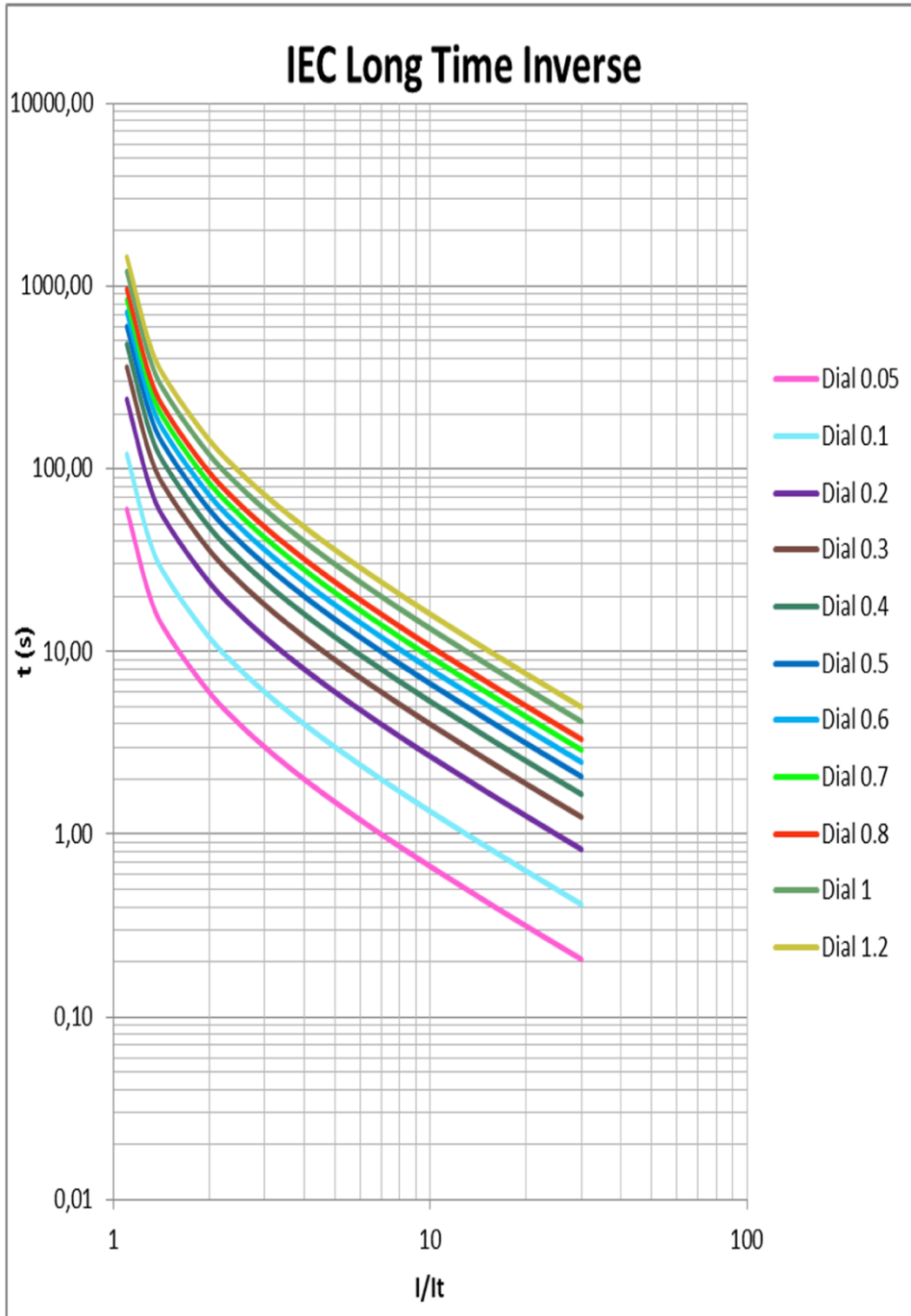

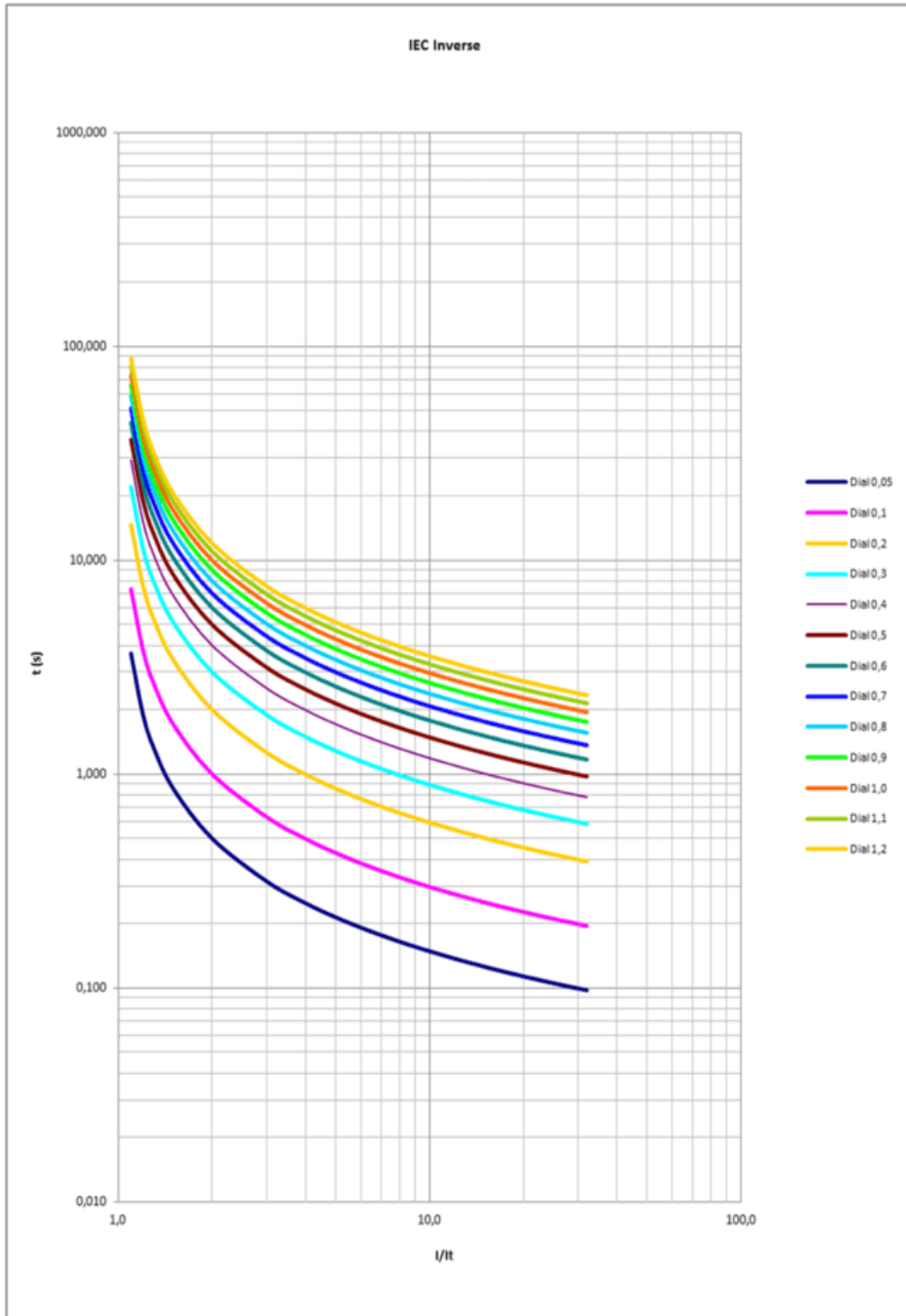

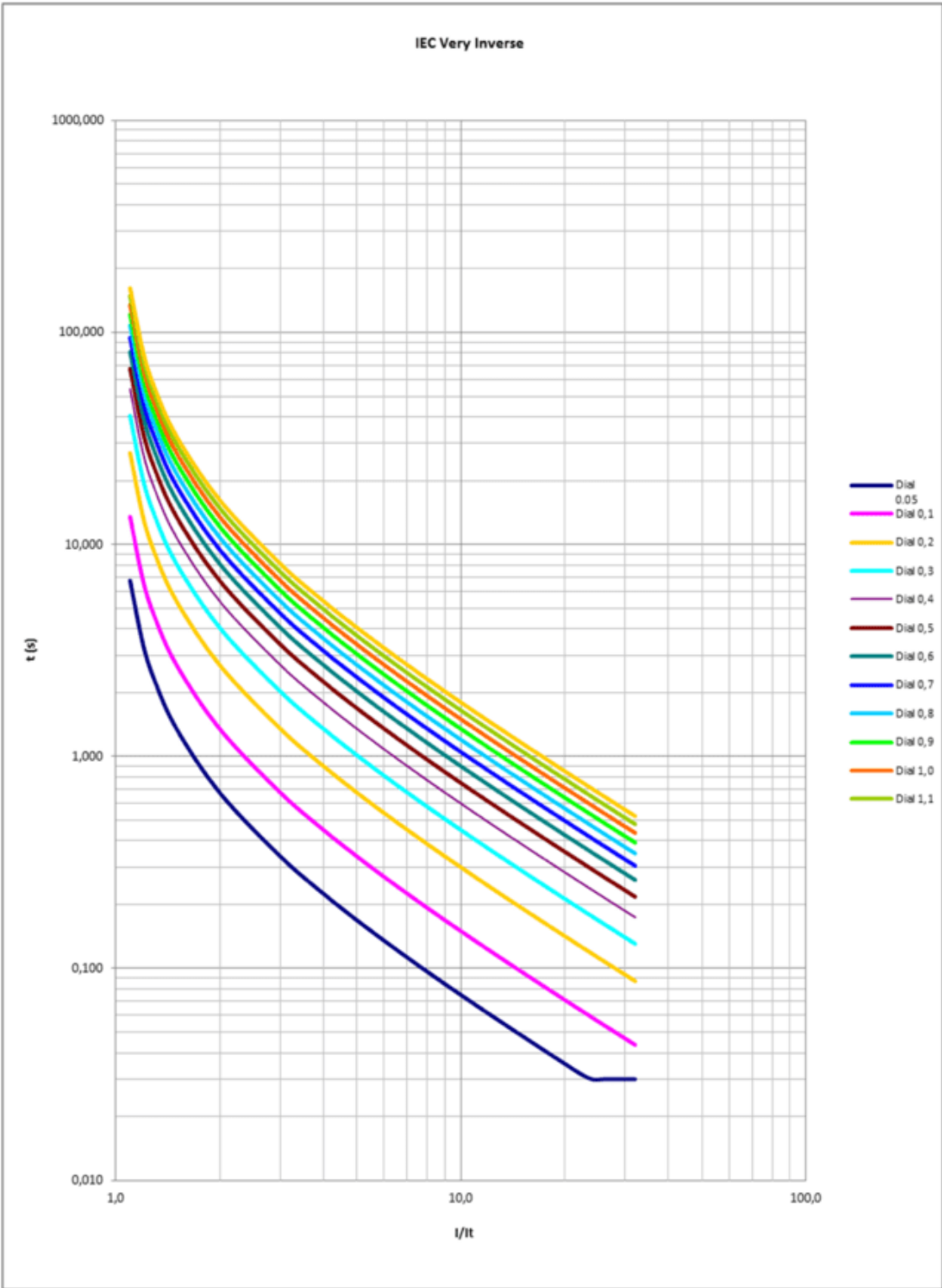

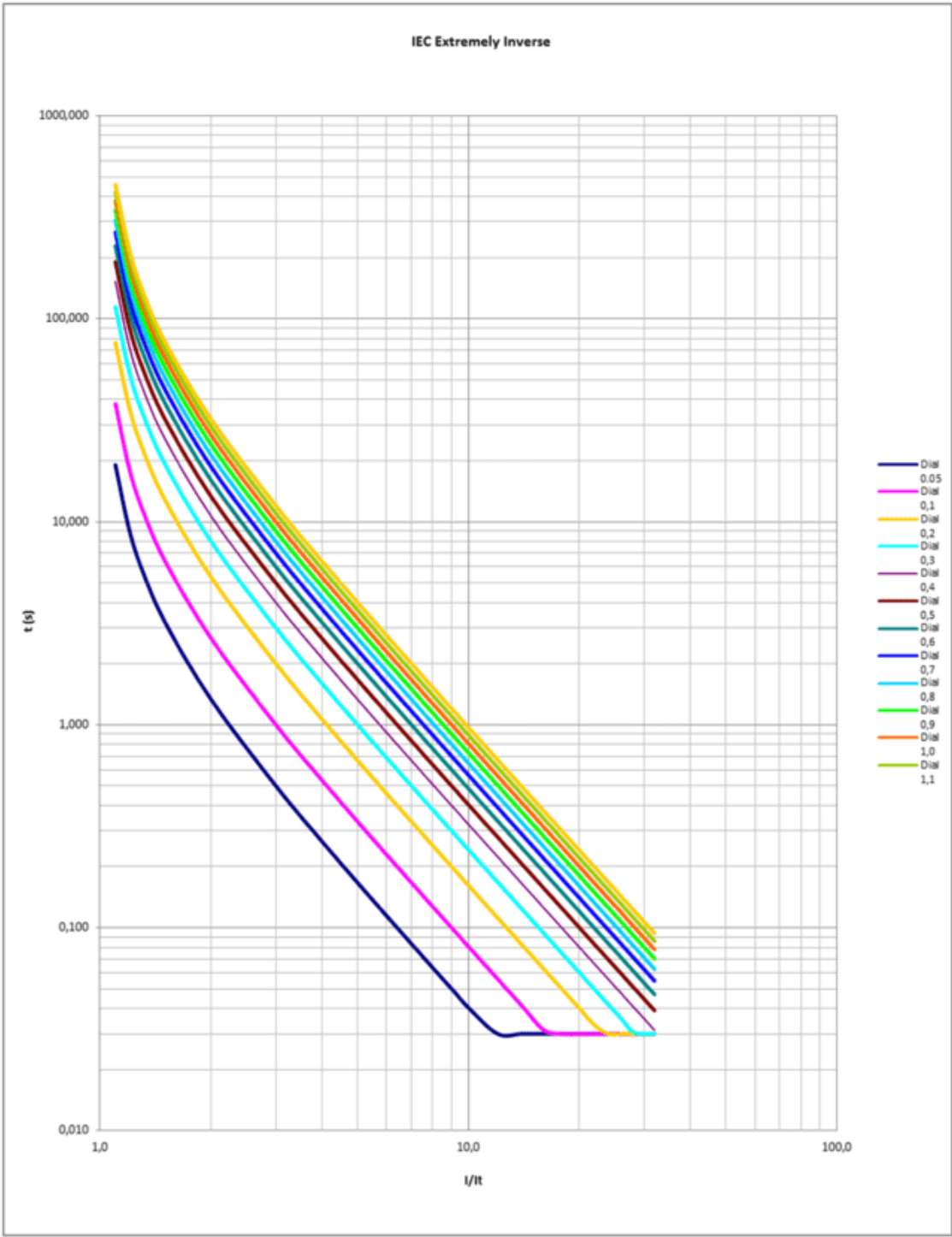

3.18 IEEE curves

The IEEE-curves follow the following mathematical equation:

$$t = (TD) \times \left[\left(\frac{A}{V^P - 1} \right) + B \right] \quad \text{where:} \quad V = \frac{I}{I_{adjusted}}$$

And we have the following curves:

- Inverse Curve
- Very Inverse Curve
- Extremely Inverse Curve

Which relate to the parameters figuring in the following Setting Group:

Parameters	A	P	B
Ext. Inverse	28,2	2	0,1217
Very Inverse	19,61	2	0,491
Inverse	0,0515	0,02	0,114

The curve can move from its axis using the TD time selection device, which the user can adjust.

I adjusted is the initial operating current, set by the user.

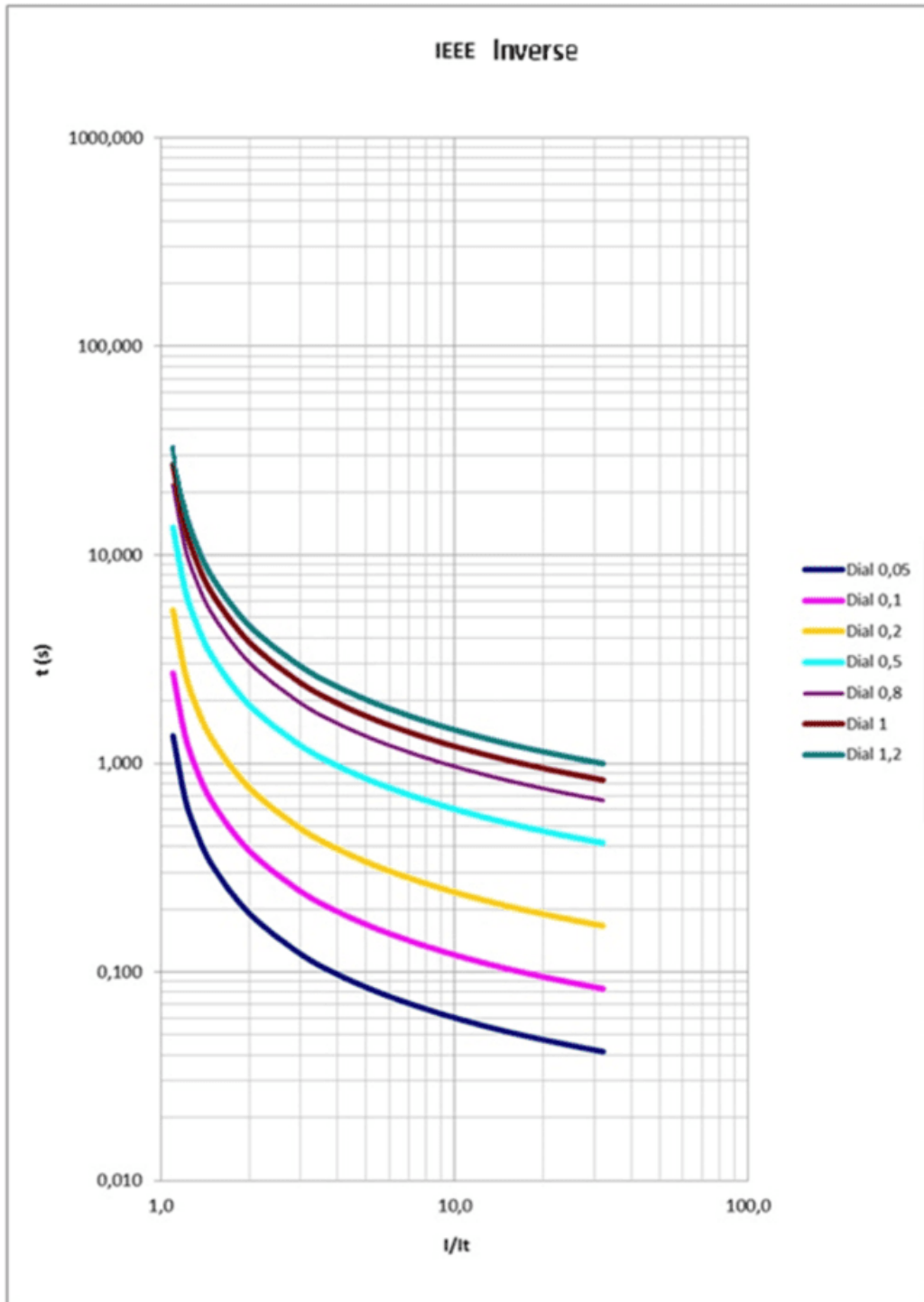

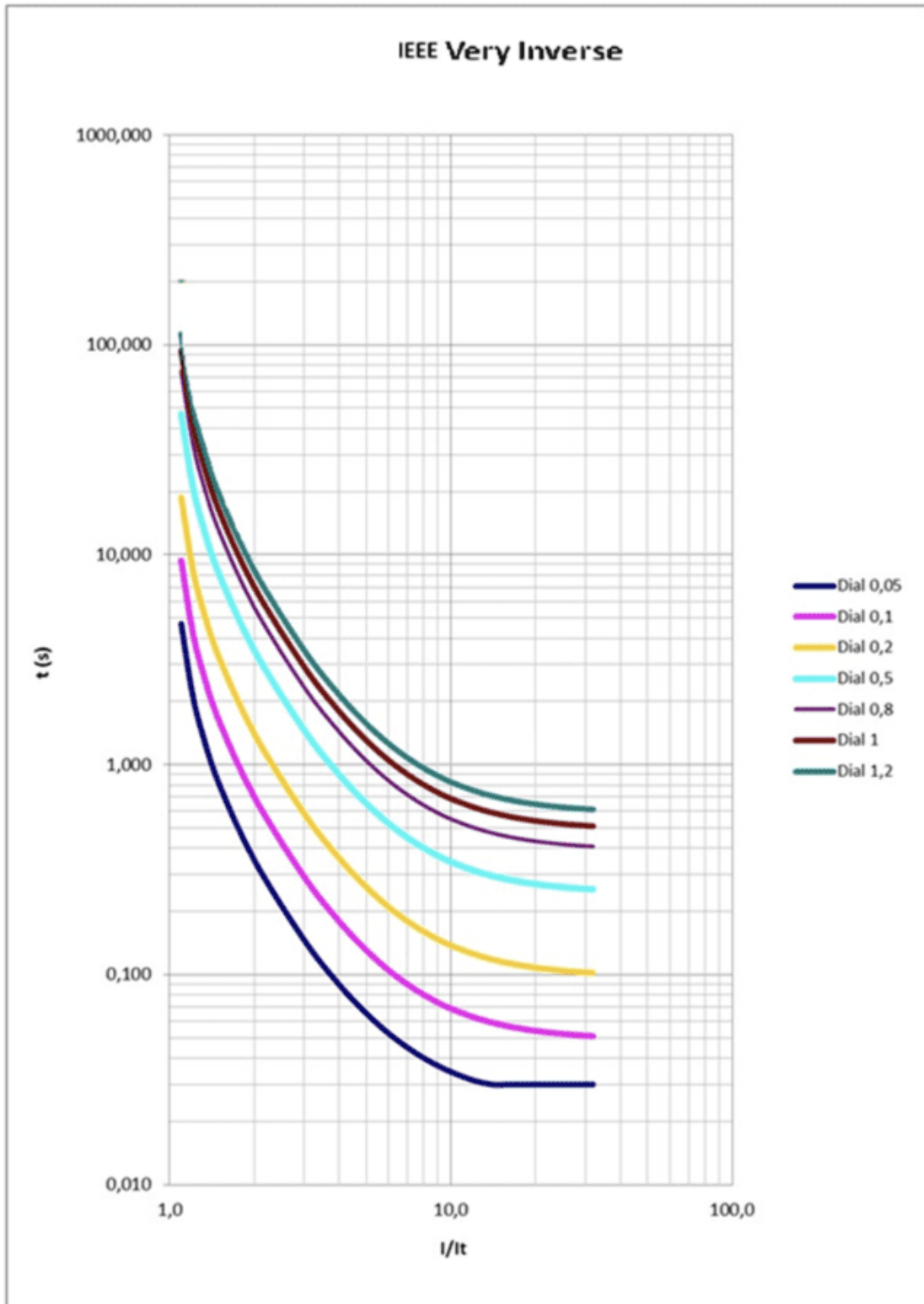

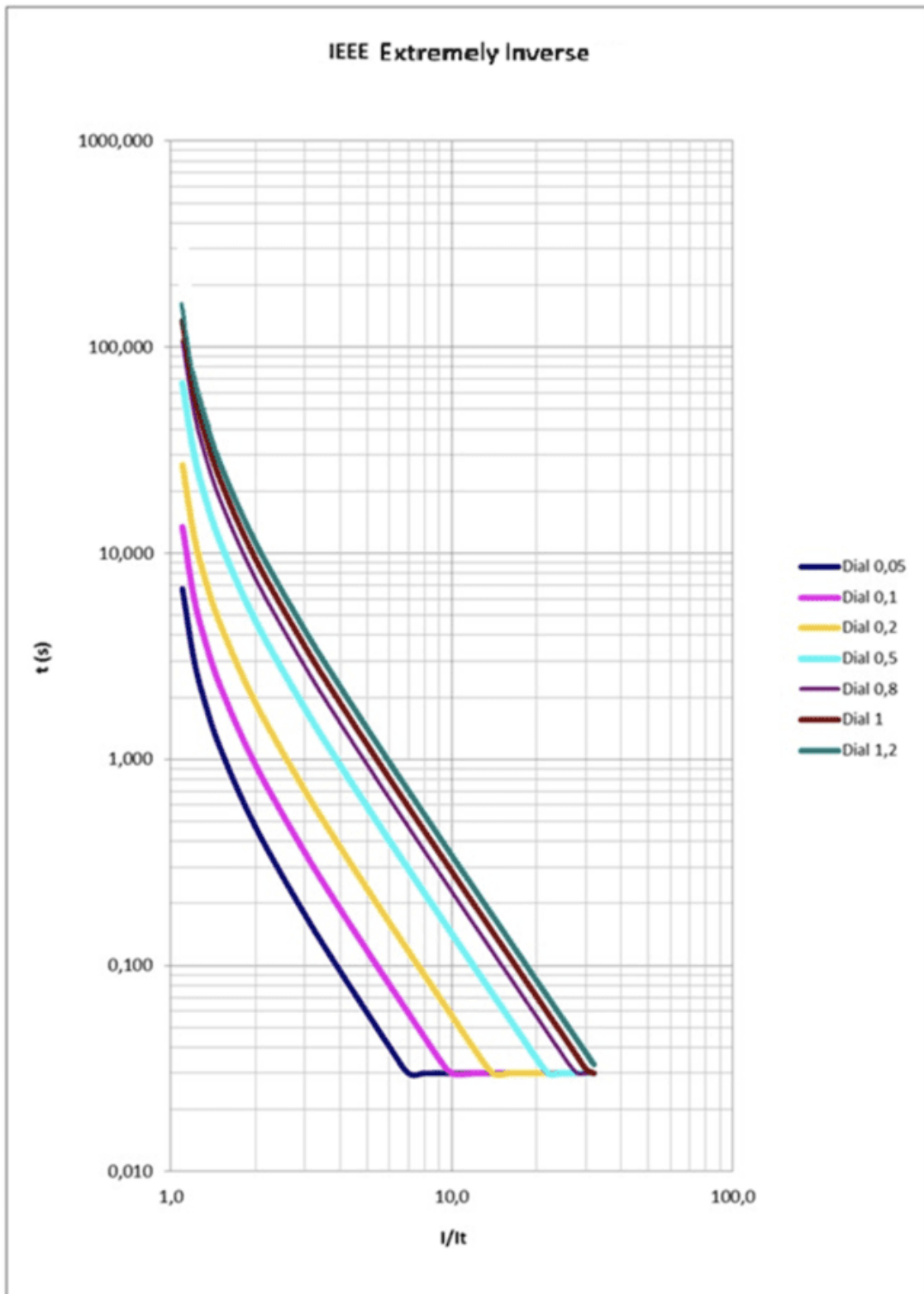

4 MONITORING AND CONTROL

4.1 Measurements

Three-phase currents (I-A, I-B and I-C), neutral current (I-N), negative sequence current (I-2), second harmonic of each phase (IA-2H, IB-2H and IC-2H), maximum current (I_{max}) and thermal image (TI) are given as fundamental values (DFT). A sampling, of 16 samples/cycle, is performed.

The accuracy of the phases and neutral measurements:

±2% in a band of ± 20% the nominal current and ±4% or ± 5 mA in the rest of the band. Phase measurement: 0.07 to 20 times the nominal current. Neutral measurement: 0.05 to 16 times the nominal current.

In case of the second harmonics currents the relay shows the measurements in amperes (although the function is set in percentage). In this case, it is necessary a minimum of 100 milliamps of the fundamental current and in terms of second harmonic the relay will not measure current if the second harmonic current is below 50 milliamps.

4.2 Load data profiling

SIA-B relay provides the demand of current with the following characteristics:

- Number of records: 168
- Recording mode circular
- Sampling rate (interval): configurable through communications: 1 - 60 min
- Record format:
Date/Time
IMAX (in interval)
IMAX (actual)
IA
IB
IC
IN



NOTE: Once the demand setting is changed, it is necessary to switch the relay off and to switch it on again to ensure that the new setting is recorded correctly.

4.3 Counters

The following counters are provided:

- 1 Number of openings of the circuit breaker
- 2 Accumulated amperes (I2t) during the openings of the circuit breaker

4.4 Deadband

The Deadband is a DNP3.0 setting. Once the deadband is set (in % of I_n), in case that the current exceeds the setting above or below, the relay will show the value of the current measurement.

Deadband of three-phase currents (I-A, I-B and I-C) and neutral current (I-N) are provided. Other measurements are set to 20% by default and it is not changeable.



NOTE: Deadband setting is only adjustable through the SICOM software.

4.5 States and events

The state is given by real-time information generated by the relay. Some states have an event associate with them, which is a register of a change made to the state. There are states that have an activation event associated with them, and other states have two associated events: activation and deactivation. These events are registered in a circular memory (buffer) with a capacity for up to 1024 events. The memory timestamp is accurate to 1 millisecond.

The events will be registered in non-volatile FRAM memory, and the events are conserved even if the relay is not powered. The relay keeps and processes the correct date and time, even without electrical power while the internal commissioning battery works (the lifetime of this battery is 20 years).

The events can be browsed from the HMI or by using communications. Reading the events does not mean that they get deleted; they remain stored on the relay. To delete the events using the HMI requires to go to the events menu and hold the “RESET” key until the number of events reads 1, corresponding this event to “Events deleted”. To delete the events using communications, use the corresponding “delete events” option. To delete the events, it is necessary to enter a password.

Events have the following structure:

Identify	Unique event identifier: e.g.: 51_1.4 = 51 START UP
Value	ON(Activated)/OFF(Deactivated): An event is generated for activations and desactivations
Associate measurement	Depending of the event
Date	Day/Month/Year Hour:Minutes:Seconds:Milliseconds

The following list shows all the states of the relay and their associated events:

Register description	State	Event	Causes	Associated measurement
General states				
	Trip	Trip	Activation/Deactivation	Maximum phase current
	External trip	External trip	Activation/Deactivation	-
	No Trip Power	No Trip Power	Activation/Deactivation	-
	50 Hz	-	-	-
	Rip Block enable	Trip Block enable	Activation/Deactivation	-
	Measure error	Measure error	Activation/Deactivation	-
	Ready	Ready	Activation/Deactivation	1: Vaux-power 2: Self-powering 4: USB Power
	Settings changed	Settings changed	Activation	-
	Set date/time	Set date/time	Activation	-
	Local Activity	Local Activity	Activation/Deactivation	-
	Factory settings	Factory settings	Activation/Deactivation	-
	EEPROM error	EEPROM error	Activation/Deactivation	-
	EEPROM changed	EEPROM changed	Activation	-
	Events error	Events error	Activation/Deactivation	-
	Reset	Reset	Activation	-
	Pickup	-	-	-
	Pickup Phase A	-	-	-
	Pickup Phase B	-	-	-
	Pickup Phase C	-	-	-
	Ground pickup	-	-	-
	Trip Phase A	-	-	-
	Trip Phase B	-	-	-
	Trip Phase C	-	-	-
	Ground trip	-	-	-
	50 Trip	-	-	-
	50G Trip	-	-	-
	Phase trip	-	-	-
	Auxiliary Power	Auxiliary Power	Activation/Deactivation	-
	Self-powering	Self-powering	Activation/Deactivation	-
	USB power	USB power	-	-
	Battery	Battery	Activation/Deactivation	-
		Identification	Activation	Access level
		New DFR	Activation/Deactivation	Fault report identifier
	Events erased	Activation	-	
Disturbance Fault Recording				
DFR	-	Reports erased	Activation	-
Definite time phase overcurrent				
50_1	50 Phase A pick-up	50 Phase A pick-up	Activation/Deactivation	Phase A current
	50 Phase B pick-up	50 Phase B pick-up	Activation/Deactivation	Phase B current
	50 Phase C pick-up	50 Phase C pick-up	Activation/Deactivation	Phase C current
	50 pick-up	50 pick-up	Activation/Deactivation	Maximum current
	50 Phase A trip	50 Phase A trip	Activation	Phase A current

	50 Phase B trip	50 Phase B trip	Activation	Phase B current
	50 Phase C trip	50 Phase C trip	Activation	Phase C current
	50 trip	50 trip	Activation/Deactivation	Maximum current
Definite time neutral overcurrent				
50G_1	50G pick-up	50G pick-up	Activation/Deactivation	Neutral current
	50G trip	50G trip	Activation	Neutral current
Inverse time phase overcurrent				
50/51	50/51 Phase A pick-up	50/51 Phase A pick-up	Activation/Deactivation	Phase A current
	50/51 Phase B pick-up	50/51 Phase B pick-up	Activation/Deactivation	Phase B current
	50/51 Phase C pick-up	50/51 Phase C pick-up	Activation/Deactivation	Phase C current
	50/51 pick-up	50/51 pick-up	Activation/Deactivation	Maximum current
	50/51 Phase A trip	50/51 Phase A trip	Activation	Phase A current
	50/51 Phase B trip	50/51 Phase B trip	Activation	Phase B current
	50/51 Phase C trip	50/51 Phase C trip	Activation	Phase C current
50/51 trip	50/51 trip	Activation/Deactivation	Maximum current	
Inverse time neutral overcurrent				
50/51G	50/51G pick-up	50/51G pick-up	Activation/Deactivation	Neutral current
	50/51 trip	50/51 trip	Activation	Neutral current
Thermal Image				
49	49 Alarm	49 Alarm	Activation/Deactivation	Thermal Image
	49 trip	49 trip	Activation/Deactivation	Thermal Image
Second Harmonic Blocking				
SHB	Phase A Block	Phase A Block	Activation/Deactivation	-
	Phase B Block	Phase B Block	Activation/Deactivation	-
	Phase C Block	Phase C Block	Activation/Deactivation	-
	Phase Block	Phase Block	Activation/Deactivation	-
Circuit Breaker Monitoring				
52	52 Start	52 Start	Deactivation	-
	52 Error	52 Error	Activation/Deactivation	-
	52 Open	52 Open	Activation/Deactivation	Opening time
	52 Opening time	52 Opening time	Activation	-
	52 Opening Error	52 Opening Error	Activation/Deactivation	Opening time
	52 Closed	52 Closed	Activation/Deactivation	Closing time
	52 Closing time	52 Closing time	Activation	-
	52 Closing Error	52 Closing Error	Activation/Deactivation	Closing time
	52 Max. Number of openings	52 Max. Number of openings	Activation/Deactivation	-
	52 Max. Accumulated amperes (I2t).	52 Max. Accumulated amperes (I2t).	Activation/Deactivation	-
52 Max. openings/time	52 Max. openings/time	Activation/Deactivation	-	
Negative Sequence Overcurrent (*)				
46	46 pick-up	46 pick-up	Activation/Deactivation	Negative sequence current
	46 trip	46 trip	Activation/Deactivation	Negative sequence current
Trip Block for switch disconnecter (*)				
TB	Phase A Block	Phase A Block	Activation/Deactivation	Phase A current

	Phase B Block	Phase B Block	Activation/Deactivation	Phase B current
	Phase C Block	Phase C Block	Activation/Deactivation	Phase C current
	Phase Block	Phase Block	Activation/Deactivation	Maximum current
Cold Load pickup (*)				
CLP	CLP Disable	-	-	-
	52 Close	-	-	-
	52 Open	-	-	-
	52 definitive Open	-	-	-
	Close Cold Load	-	-	-
	Open Cold Load	-	-	-
	Cold Load pickup	Cold load pickup	Activation/Deactivation	Phase current
Breaker Failure Supervision (*)				
50BF	50BF pick-up	50BF pick-up	Activation/Deactivation	Phase current
	50BF trip	50BF trip	Activation/Deactivation	Phase current
Inputs				
	Input 1	Input 1	Activation/Deactivation	-
	Input 2	Input 2	Activation/Deactivation	-
	Input 3	Input 3	Activation/Deactivation	-
Outputs				
	Trip Output	Trip Output	Activation/Deactivation	-
	Output 1	Output 1	Activation	-
	Output 2	Output 2	Activation	-
	Output 3	Output 3	Activation	-
Leds				
	Led 1	-	-	-
	Led 2	-	-	-
	Led 3	-	-	-
Logic				
	52 A	52 A	Activation/Deactivation	-
	52 B	52 B	Activation/Deactivation	-
	External trip	External trip	Activation/Deactivation	-
	Block 50/51	Block 50/51	Activation/Deactivation	-
	Block 50/51G	Block 50/51G	Activation/Deactivation	-
	Settings Group 1	Settings Group 1	Activation/Deactivation	-
	Settings Group 2	Settings Group 2	Activation/Deactivation	-
	Reset	Reset	Activation/Deactivation	-
	Logic Signal 1	-	-	-
	Logic Signal 2	-	-	-
	Logic Signal 3	-	-	-
	Logic Signal 4	-	-	-
Local communication				
	Local communication	-	-	-
	HMI Activity	-	-	-
	Open Breaker	Open Breaker	Activation	2 (Command identifier)
	Close Breaker	Close Breaker	Activation	2 (Command identifier)
	Reset thermal image	Reset thermal image	Activation	10 (Command identifier)
Remote communication (*)				
	Remote communication			
	Open Breaker	Open Breaker	Activation	2 (Command identifier)
	Close Breaker	Close Breaker	Activation	3 (Command identifier)
	Reset thermal image	Reset thermal image	Activation	10 (Command identifier)

A brief description of the general states is given below:

- **Trip:** The relay has tripped.
- **External trip:** A trip has been caused by the activation of the excess temperature input (external trip).
- **50 Hz:** If activated, the relay works at 50 Hz, if deactivated it works at 60Hz.
- **Trip Block Enable:** If the Trip Block functions is available in the model, it has been enabled.
- **Measure error:** The self-diagnosis algorithms have detected a problem in the measurement block.
- **Ready:** No errors
- **Setting change:** Activated when the settings are changed.
- **Date-time set:** Activated when the date-time are synchronized.
- **Local communication:** this is the sum of the “HMI activity” and “Local communication” bits from the “Local communication” state group
- **Remote communication:** “Remote communication” bit from the “Remote communication” state group
- **Factory settings:** the relay is set to default settings and does not execute the trip.
- **Eeprom Error:** The self-diagnosis algorithms have detected a problem in the Eeprom memory, which contains the settings.
- **Eeprom change:** Activated when the settings or configuration (user passwords) are changed.
- **Events error:** since the events buffer is circular, new events overwrite the older events once the buffer is full, and the older events are lost. To show this situation, the “Events error” bit is activated. This bit is reset by deleting the events (from the HMI or by using communications).

4.6 Date and Time by Real Time Clock (RTC)

The Protection devices require a clock, enabling them to have a date and time stamped for events and registers. This clock is maintained while the internal commissioning battery works (the lifetime of this battery is 20 years).

This clock can be synchronized by any of the two following procedures:

- From the HMI. In this case the date and time can be entered via the keyboard. The relay will store the new event indicating that it has been synchronized.
- Protocol. The behavior is identical to the HMI. The relay will synchronize the date and time, and a new synchronization event is carried.

4.7 Self-diagnosis

Diagnostic algorithms are run while the relay is being started up and continuously when the relay is operating. This diagnostic is a preventative process to guarantee that the relay is in good operational condition.

As general considerations:

- Communications between different CPUs are confirmed by the corresponding integrity checking. If continuous anomalies are detected, the relay will be reset.

- Data related to set values are confirmed by the corresponding checking. Likewise, all setting groups are doubled, and the relay has the capability for working with a damage setting group, but not with two damaged setting groups.
- There is a Watchdog device both between and in main CPUs. If any CPU goes out of operation the relay will be reset and this condition will be identified as an event.

The following state bits are associated with this process:

Measurement error	Problem in the measurement block
No Trip Power	There is not the required energy to trip
Eeprom error	Problem in the Eeprom memory, some Group is corrupted. Remaining that setting (both Group) are duplicated in Eeprom chip.
Events error	Problem on the events recording
Date & time error	Problem recording the date & time (the relay records an invalid date & time)

No Trip Power message indicates the relay has not enough energy to trip. This situation is not permanent, and it is solved once the relay achieves the necessary energy to trip thank to when enough time has passed, more current is injected or other auxiliary supply is used.

The other errors are related with the communication of the 2 microprocessors that are included in the relay.

Measurement error event always is generated when the BATTERY key is pressed because when this key is pressed only one of the microprocessors is operative.

If this problem occurs with a model without commissioning battery and appear on the standby screen or any of the other 2 situations appear on the main screen (**EEPROM ERROR** or **EVENTS ERROR**), the relay should be replaced, and it will be necessary to contact Mevoco.

On the other hand, "Default settings" means that the relay is operating under factory settings, being all protection functions disabled.

4.8 Disturbance Fault Recording

Disturbance fault recording includes the disturbance records in COMTRADE format and the data of each COMTRADE (fault reports). The relay can store, in FRAM memory, up to 20 fault reports with 16 events in each. From the standby mode screen, press “OK” key to access the first line of menus. Use the “▲” and “▼” keys to position the cursor over the “FAULTS” screen. They are also accessible pressing “◀” from the standby menu. The next information can be checked:

- Date-time at which the fault started.
- List of all events occurred in the relay during the fault.

To delete the fault reports buffer, position the cursor over the fault report menu and press and hold the “RESET” key, until there are no fault reports. There will be an event “Fault reports erased”.

Besides, the relay can store the last 10 fault reports in COMTRADE format – cyclic recording by FIFO method (with 50 cycles per record – resolution 16 samples/cycle). The first three of these cycles correspond to pre-fault.

The DFR starts when a function pickup happens and the DFR will take place when the trip is finished or when the record is full.

The COMTRADE file is downloaded by communications through the front or rear port using the Modbus protocol. The SCom communications program allows the user to download and save the reports in COMTRADE format (IEEE C37.111-1991).

Once the COMTRADE is saved 3 files are generated:

- ".dat" bestand: De informatie van het COMTRADE-record in gegevensformaat.
- ".cfg"-bestand: De informatie van de COMTRADE-record in grafisch formaat (dit is het bestand dat moet worden geopend om de bij de DFR betrokken golven en signalen te analyseren).
- ".hdr"-bestand: Dit is het COMTRADE header-bestand dat het volgende bevat: datum en tijd van de record, het COMTRADE-recordnummer, de pre- en post-foutcycli en de analoge/digitale kanalen.

The format of a COMTRADE header file can be shown below:

The following additional information is included in the COMTRADE header file (*.hdr): date-time, number, relay identification and a list of all the events that occurred in the relay while COMTRADE file was being generated.

Shown below is the format of a COMTRADE header file, generated by the SCom program:

***** HDR COMTRADE*****

The following information is included in each COMTRADE file:

Number	Analog channels
1	Phase A current
2	Phase B current
3	Phase C current
4	Neutral current

This current is already in primary amperes.

As well as the analogue magnitudes, the relay saves 32 digital records, with the same precision as 16 cycle samples. These 32 bits are as follows:

	Digital channels
1	50_1 trip
2	50G_1 trip
3	50_2 trip
4	50G_2 trip
5	51 trip
6	51G trip
7	46 trip
8	49 trip
9	External trip
10	Trip
11	52
12	Trip output
13	50_1 Phase A pick-up
14	50_1 Phase B pick-up
15	50_1 Phase C pick-up
16	50G_1 pick-up
17	50_2 Phase A pick-up
18	50_2 Phase B pick-up
19	50_2 Phase C pick-up
20	50G_2 pick-up
21	51 Phase A pick-up
22	51 Phase B pick-up
23	51 Phase C pick-up
24	51G pick-up
25	50BF trip
26	Cold Load Pick-up
27	No Trip Power
28	SHB
29	Phase Block
30	Output 1
31	Output 2
32	Output 3

It is possible to visualize the COMTRADE file using SICom software:

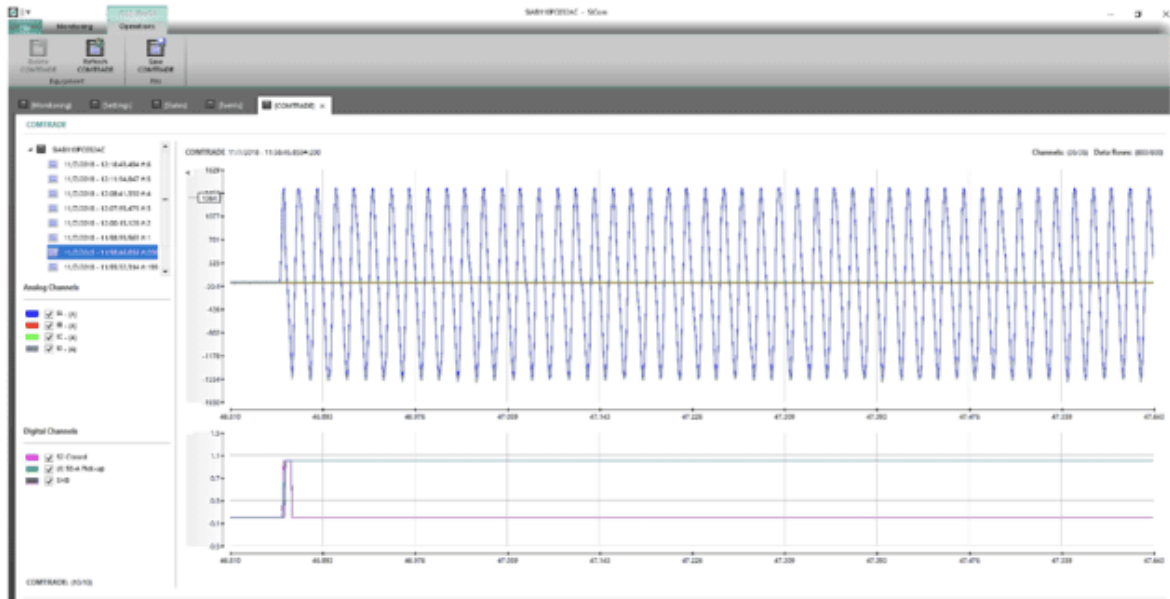

Using SICom software, it is possible to save the COMTRADE file.

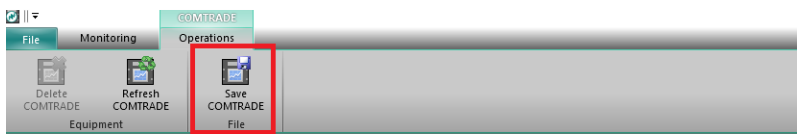

4.9 Configurable Inputs

The SIA-B is provided with 3 digital inputs that can be configured by the user from the HMI or by using the SiCom program.

The default input configuration is shown below:

Logic	In 1	In 2	In 3
52 a	-	-	-
52 b	-	-	-
External trip	✓	-	-
Block 50/51	-	-	-
Block 50/51G	-	-	-
Settings group 1	-	✓	-
Settings group 2	-	-	-
Reset	-	-	✓
Logic signal 1	-	-	-
Logic signal 2	-	-	-
Logic signal 3	-	-	-
Logic signal 4	-	-	-

4.10 Digital Outputs

Optionally (to be selected for each model), the SIA-B relay is provided with 3 configurable outputs. By default, the configuration is as follows:

- Output 1: it is activated if the relay is not ready (Watchdog)
- Output 2: it is activated when any of the phase functions trip
- Output 3: it is activated when any of the ground functions trip

To get the outputs all together to be operative at the same time, it is required Single phase→305 mA or Three phases→170 mA. To activate an output it is required Single phase→270 mA or Three phases→90 mA. Once the relay detects these levels of current these outputs are instantaneously operative.

4.11 Programmable Logic Control

SIA-B relay is provided with 4 configurable LEDs. Besides, up to 3 configurable outputs can be included (*Output 1, Output 2 and Output 3*). Consider, the trip output, although is available in configuration menu, cannot be configured due to its design is associated to the opening mechanism.

LEDS	LED 1
	LED 2
	LED 3
	LED 4
Outputs	Output 1
	Output 2
	Output 3
	Trip Output (NON-CONFIGURABLE)

4.11.1 Outputs

All the outputs (Physical outputs) are the result of a PROGRAMMABLE LOGIC CONTROL which can be configured from HMI or from SICom software.

For each output, there is a LOGICAL GATE. It can perform a logical operation up to 4 binary states to obtain other binary result. In V3 of the PGC the LOGICAL GATES that are supported by SIA-B are:

SORTIE LOGIQUE	Symbole IHM
OR4	+
NOR4	τ
AND4	&
NAND4	§
OR4 LACTH	Ю
OR4_PULSES]
OR4_TIMER_UP	O
OR4 PULSE	o
NOR4_TIMER_UP	P
NOR4_PULSE	p
NOR4_PULSES	t
AND4 LACTH	Φ
AND4_PULSES	\$
AND4_TIMER_UP	Q
AND4 PULSE	q
NAND4_TIMER_UP	R
NAND4 PULSE	r

(*) When the logical gates (LATCH, TIMER_UP, PULSES or PULSE) are added to the standard gates (OR/NOR/AND/NAND) it is necessary to switched the relay off and to switch it on again (due to this configuration requires the setting of a time that will be charged in the relay only when it is switched off).

NOTE: As it is described above, the options NOR_LATCH, NAND_PULSES and NAND_LATCH are not available in the relay. Although, using SICOM software allows the user to configure these options, the relay will not recognize them and it will not work properly.

By default, the configuration is:

	OUTPUT	LOGICAL GATE	BINARY STATE
PHYSICAL OUTPUT	Output 1	NOR4	Ready
	Output 2	AND4	Phase trip General trip
	Output 3	AND4	Ground trip General trip
	Trip Output	OR4_PULSES	General trip
LOGIC	52 a	Not configured	-
	52 b	Not configured	-
	External trip	OR4	Input 1
	Block 50	Not configured	-
	Block 50G	Not configured	-
	Settings group 1	OR4	-
	Settings group 2	Not configured	-
	Reset	OR4	Input 3
	Logic signal 1	Not configured	-
	Logic signal 2	Not configured	-
	Logic signal 3	Not configured	-
	Logic signal 4	Not configured	-

Function 86 (latch condition) can be implemented through signaling outputs configuration. It is necessary to configure one of the signaling outputs as trip output and after this configuration if OR4_LACTH is chosen the latch of this output is being permitted.

4.11.2 Leds

In case of LEDs the behavior is different to the outputs. The only available configuration is as follows:

LOGICAL GATE	HMI SYMBOL
OR4	+
NOR4	τ
AND4	&
NAND4	§

Depending on the associated signal the signaling will offer 2 options:

After being switched off, when the relay is switched on again, the LEDs should show the state just before being switched off. For this reason, and to have as much information as possible, the LEDs will light up in a different way depending on if the user has recognized the LED before the switched off or not. To recognize the LEDs, it is necessary to hold RESET key from standby menu.

So, the LEDs will light as follows:

SIGNAL ASSOCIATED TO THE LED KEEPS ITSELF ACTIVATED

The signal that origins the activation of the LED remains activated (the LED and the associated signal are activated at the same time): In this case the LED will blink at a fixed frequency. Once the LED is recognized, it will still be blinking with a different frequency.

If after being recognized, the associated signal is deactivated, the LED will be switched off.

SIGNAL ASSOCIATED TO THE LED IS SWITCHED OFF BEFORE BEING RECOGNIZED

If the signal that origins the activation of the LED does not remain activated, once this associated signal is deactivated the LED will be fixed. Once the LED is recognized, the LED will be switched off (due to the signal that provoked its activation is deactivated).

By default, the configuration is:

	Output	Logical gate	BINARY STATES
L E D S	LED 1 (green)	OR4	Ready
	LED 2 (green)	AND4	Ground trip General trip
	LED 3 (green)	AND4	Phase trip General trip
	LED 4 (green)	OR4	Thermal trip

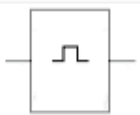

The configured signal will make a pulse of the adjusted milliseconds once the input signal is activated.

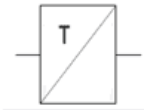
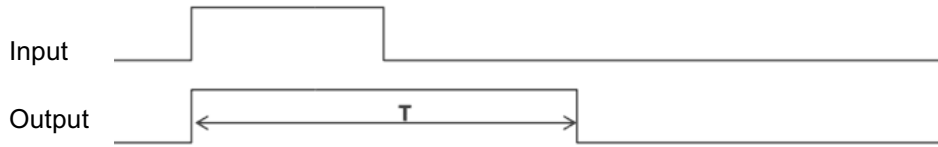

The configured signal waits the adjusted milliseconds to activate itself.

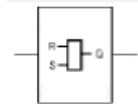
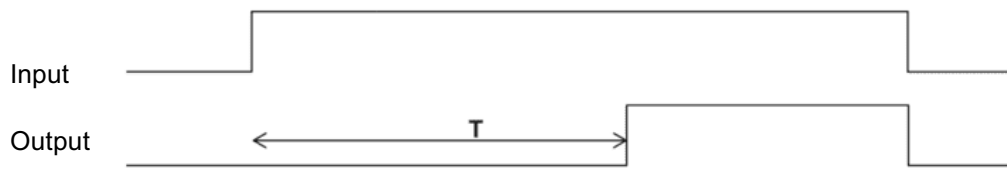

The configured signal will be activated till it is externally reset (command, reset key, Communications ...), though the input signal drops off.

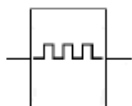
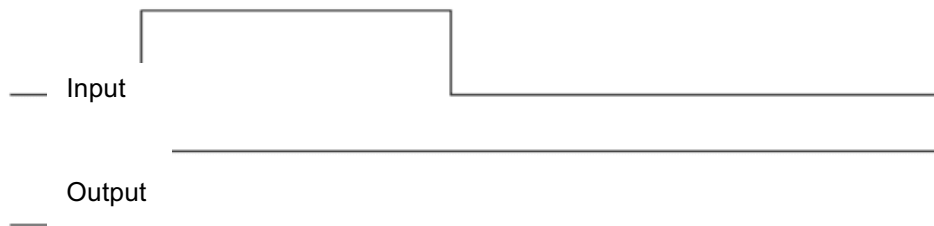

The configured signal will make pulses of the adjusted milliseconds while the input signal is activated.

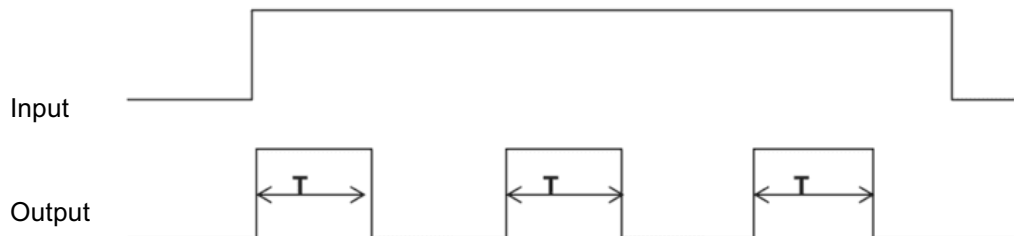

4.12 Commands

By HMI or by communications, depending on model is possible to:

- Open Breaker
- Close Breaker
- Reset Thermal Image

When Open Breaker command is performed, the trip output is activated (originating the corresponding event) and the message “trip general” will be displayed on main screen.

4.13 Test Menu

The SIA-B relay has a test menu that can be used to check the operation of the signaling components and the outputs. It is important to point out that the operation of the outputs does not work if the test is performed with the commissioning battery.

Press ◀, ▼, ▶ sequentially and hold OK until the “Test menu” appears on the display. The relay will ask for the password “5555” to be entered in the test menu (or other if the customer password by default is “5555” has been modified).

The test menu is accessed by pressing the “OK” key again, and the “▲” and “▼” keys can be used to navigate through the different menu items. Each item can be activated or deactivated by pressing “OK” on it (if the item is deactivated, it is activated by pressing OK; if the item is activated, it is deactivated by pressing “OK”). Press the “C” key to exit the test menu.

Once the relay is in test menu mode all the LEDs will be activated simultaneously. In case of the outputs, they will be activated or deactivated by pressing OK key:

Output 1	Deactivated	Output 1 Deactivated
	Activated	Output 1 Activated
Output 2	Deactivated	Output 2 Deactivated
	Activated	Output 2 Activated
Output 3	Deactivated	Output 3 Deactivated
	Activated	Output 3 Activated
Trip Output	Deactivated	Trip Output Deactivated
	Activated	Trip Output Activated

Once each output is activated/deactivated the corresponding event will be recorded in the relay.

NOTE: When performing the test menu, the protection will not be available, and it will be possible to open the circuit breaker. Only authorized personnel can do this job. To obtain more detailed information, the method for navigating the menus is explained graphically in the keypad and display section.

4.14 Power supply

The SIA-B relay is designed to be self-powered using the cell current. Besides, depending on model it is possible to select apart from self-powered an auxiliary supply (24-230 Vdc/Vac +10%/-20% (Dual)).

It can also be supplied from a USB cable which goes directly to the PC. The USB is plugged into the front communications port. Using USB cable for power supply does not inhibit the USB communications port, as it can be used simultaneously.

4.14.1 Self-Powered relay with standard current transformers

The SIA-B powers itself from the operating current through standard current transformers that are connected to the line. Self-powering is achieved with very low levels of current: a minimum of 75 mA three phase current or 160 mA one phase.

The relay is maintenance free when this type of power supply is used, as it does not require auxiliary power components (batteries). As a result, it is especially useful in any centers where auxiliary power is not available or cannot be guaranteed, and the facilities require protection with low levels of current.

There is a self-power transformer per each phase (3 self-power transformers), separating current circuits completely.

4.14.2 24-230 Vac, 50/60 Hz auxiliary power

The 24-230 Vac (+10%/-20%) auxiliary powers are taken from the transformation center secondary voltage. If this option is required, this needs to be selected in the list of models.

It is normal for transformation substations to have auxiliary voltage. This voltage is not guaranteed because a short-circuit may cause this auxiliary voltage loss. However, the complete auxiliary voltage loss is produced in primary faults between phases, which are very unlikely and generate a lot of current. In other words, for faults with low contribution of current, AC auxiliary voltage keeps its level and supplies the relay and for faults with auxiliary voltage sag and high contribution of current, the self-powering characteristic keeps the relay operative. The continuous operation of SIA- B is guaranteed with the levels of self-powering (75 mA three phase current or 160 mA one phase) and the auxiliary power supply 24-230Vac.

4.14.3 24-230 Vdc auxiliary power supply

The 24-230 Vdc (+10%/-20%) auxiliary power is taken from the transformation center RTU power supply. SIA-B consumes a maximum of 0.5 W in normal operation. The consumption is so reduced that it practically does not affect the transformation substation battery of 24Vdc, being able to supply from it, with a total guarantee and without being a loss of functionality with communications relay because it will extract 20 mA/hour. Therefore, the relay can be powered all the time, allowing it to be continually monitored (status, measurements of transformation center current, events...). The relay is totally operational at this power and if a fault occurs, the trip time matches the time setting. In a situation where the center is deenergized, if this is energized and a fault induced with the instantaneous function set at 20 ms, the trip time will be 20 ms.

4.14.4 Battery power: 5 V, with a KITCOM adaptor

The external 5 V battery is connected to the relay through an adaptor that is plugged into the front communications port (KITCOM). It is useful for cases like commissioning operations, discharges and repairs to the transformation center, as these are situations when there is no auxiliary voltage or current in the line and they normally cause more events, grounding, forgotten tools, bad terminations, etc.

Battery power guarantees the full operation of the relay, including the trip. The possibility of using external battery power, together with the possibility of activating the trip contact from the test menu, allows the trip circuit to be tested before the transformation center is powered up.

Using battery power does not block the USB communications port, as it can be used simultaneously. When the relay is being powered from a 5 V battery, it is capable of functioning for 4 hours.

The relay can also be powered through a USB cable connected directly to the laptop or through a conventional powerbank.



4.14.5 Commissioning battery

A specific key is available in the front part of the relay.

Pressing this key, it is possible to switch the relay on and navigate through the different menus. Thanks to this option, the user can check all the information recorded during the fault. This is, checking the

events and the fault reports is possible and this action allows the user to know all the information regarding the fault situation.

The working of the relay is independent from the internal battery. This battery is just an accessory that allows the user to set the relay and to analyze the information recorded in fault reports and events menus, but it does not take part on the main working of the relay.

Once you press the Battery key, the relay is switched on for 15 seconds if no key is pressed.

If the relay is powered with other type of supply, pressing the battery key has not any effect in the relay.

If the relay is switched on by pressing battery key and then other power supply is connected to the relay, the relay considers automatically the new power supply.

When this key is pressed an event called “battery” and an event of Measure Error is generated. This last event is originated because once this key is pressed, only one microprocessor is activated and there is no communication between the microprocessors.

The lifetime of the battery is 20 years.

How to change the internal battery

1. Disconnect the relay. Switch the power supply off to avoid any dangerous situation.
2. Unscrew the 4 screws on the front of the relay to extract it from the RMU switchgear.

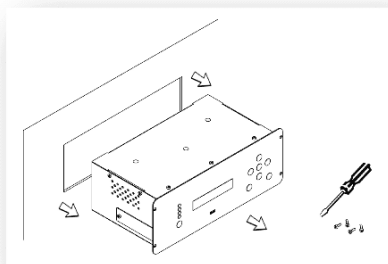
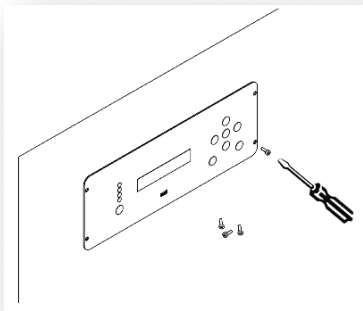

3. Access to the rear side of the relay.

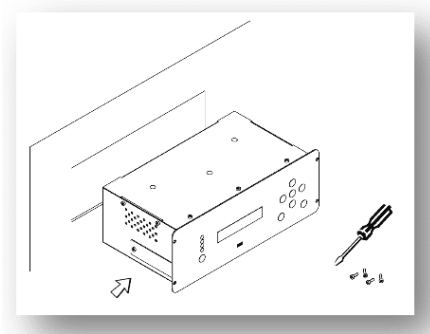

4. Unscrew the 2 screws to remove the cover from the battery compartment.

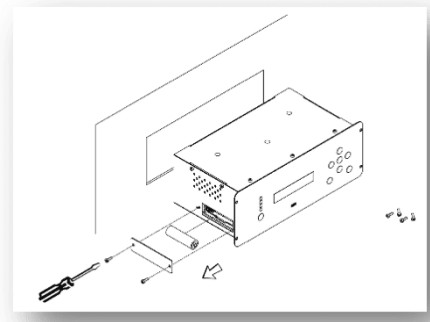

5. Remove the battery and replace it respecting polarity (+ facing up) :

Battery characteristics:

- 1 AA 3.6V lithium battery
- 2 Model LS14500 from SAFT
- 3 Do not use rechargeable batteries or other types of battery

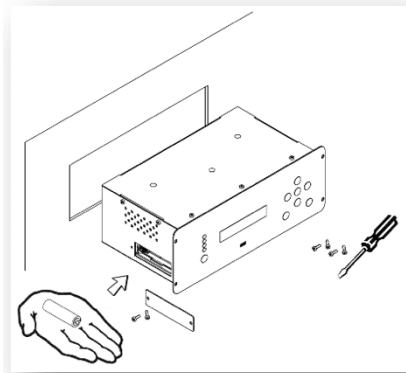

6. Put on the battery cover and tighten the 2 screws.

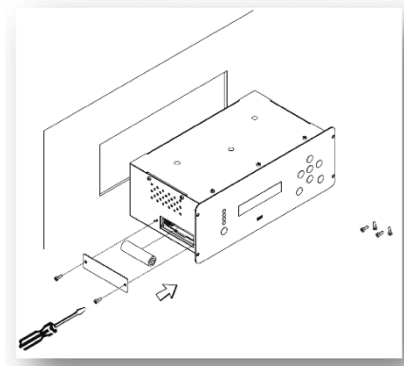

7. Put the relay into the RMU switchgear and tighten the 4 screws on the front to fix the relay.

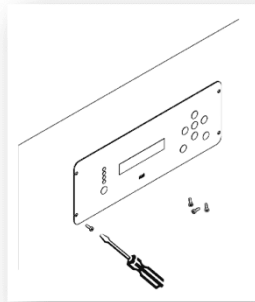
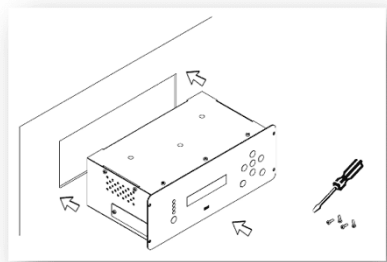



Warning

HAZARD OF EXPLOSION

- Do not recharge the battery.
- Do not short circuit the battery.
- Do not crush the battery.
- Do not disassemble the battery.
- Do not heat the battery above 100°C (212°F).
- Do not throw the battery into fire or water.

Failure to follow these instructions can result in death, serious injury, or relay damage.

4.15 Switch on to fault (SOTF) characteristic

SIA-B is an electronic device, which provides a starting up time (time from relay activation to operational capacity). Logically, it is a desirable to have a minimum time for the starting up the relay.

Depending on cases, it is a desirable to assess the necessity of a fast tripping time during the start of the relay. In installations with guaranteed auxiliary voltage, the relay gets the energy for the trip in a very short time. It also depends on the type of striker which will be used: there are strikers which need less energy for their activation.

This tripping time depends on the setting “Trip Voltage Level” as well. At equal supplied current (low levels of current), a greater value of this setting implies a longer time to trip because the relay requires more time to achieve the necessary energy for the trip. At high levels of current, this setting may have no effect on the tripping time because the energy is easy and quickly achieved.

The most critical case is produced when the relay is self-powered (without auxiliary voltage or battery) and low current faults.

4.16 Opening mechanism: STRIKER

Polarized: The trip is associated to a striker. The type of trip is a polarized trip, this is, the trip is associated to a striker. There are a lot of models of strikers in the market, with different trip energies, being for example 50 mJ (0.05W·s) and operation voltage of 6V, or 135 mJ (0.1W·s) and operation voltage of 24V.

The opening mechanism is activated by means of a striker. The activation of the trip generates a pulse train.

The **Trip Voltage Level** setting allows adjusting the trip voltage level required by the selected striker. The default value is 12 Vdc, although there are several options:

- 12 Vdc
- 17 Vdc
- 22 Vdc
- 24 Vdc

The relay will allow the trip when it gets the selected trip voltage, so if a lower level that the required by the striker is adjusted, it may result on tripping without enough energy and not activating the striker.

On the other hand, if a higher level that the required by the striker is selected, the activation of the striker is guaranteed, however, the fault trip time during start-up may be increased. MEVOCO encourages selecting the correct value of this critical setting and offers its expertise at any doubt.

The activation of the SIA-B trip output means that a capacitor has discharged on the output terminals. This discharge of energy is enough to activate a striker that mechanically acts on a mechanism to open the current circuit. The striker is connected directly to the SIA-B output, which supplies enough power to activate it (24 Vdc - 135mJ).

5 TECHNICAL SPECIFICATIONS AND STANDARDS

5.1 Technical Specifications

50_1	Function Enable: Yes/No/SHB
	Current Tap: 0,2 to 20 xIn (not 0,01 xIn)
	Time Delay: 0,02 to 2 s (step 0,01 s)
	Activation level: 100%.
	Deactivation level: 95%.
	Instantaneous deactivation
	Timing accuracy : Without SHB permitted: ± 30 ms or $\pm 0,5\%$ (greater of both). With SHB permitted: ± 50 ms or $\pm 0,5\%$ (greater of both).
50G_1	Function Enable: Yes/No/SHB
	Current Tap: 0,2 to 20 xIn (not 0,01 xIn)
	Time Delay: 0,02 to 2 s (step 0,01 s)
	Activation level: 100%.
	Deactivation level: 95%.
	Instantaneous deactivation
	Timing accuracy : Without SHB permitted: ± 30 ms or $\pm 0,5\%$ (greater of both). Met SHB toegestaan: ± 50 ms or $\pm 0,5\%$ (greater of both).
51	Function Enable: Yes/No/SHB
	Curves: IEC 60255-151 and IEEE curves. IEC (inverse curve, very inverse curve, extremely inverse curve, long time inverse, short time inverse) en IEEE (inverse curve, very inverse curve, extremely inverse curve).
	Time Delay: 0,02 to 3 s (step 0,01 s)
	Time Dial (TMS): 0,01 to 1,50 (step 0,01)
	Curve, activation level: 110%.
	Curve, deactivation level: 100%.
	Defined time, activation level: 100%.
	Defined time, deactivation level: 95%.
	Instantaneous deactivation
	Timing accuracy for IEC- and IEEE-curve selection: Without SHB permitted: ± 30 ms or $\pm 5\%$ (greater of both). With SHB permitted: ± 50 ms or $\pm 5\%$ (greater of both).
	Timing accuracy for defined time selection: Without SHB permitted: ± 30 ms or $\pm 0,5\%$ (greater of both). With SHB permitted: ± 50 ms or $\pm 0,5\%$ (greater of both).
51G	Function Enable: Yes/No/SHB
	Curves: IEC 60255-151 and IEEE. IEC (inverse curve, very inverse curve, extremely inverse curve, long time inverse, short time inverse) and IEEE (inverse curve, very inverse curve, extremely inverse).
	Time Delay: 0,02 to 3 s (step 0,01 s)
	Time Dial (TMS): 0,01 to 1,50 (step 0,01)
	Curve: 0,2 to 7 xIn (step 0,01 xIn)
	Curve, activation level: 110%.
	Curve, deactivation level: 100%.
	Defined time, activation level: 100%.
	Defined time, deactivation level: 95%.
	Instantaneous deactivation
	Timing accuracy for IEC- and IEEE-curve selection: Without SHB permitted: ± 30 ms or $\pm 5\%$ (greater of both). With SHB permitted: ± 50 ms or $\pm 5\%$ (greater of both).

	Timing accuracy for defined time curve selection: Without SHB permitted: ± 30 ms or $\pm 0,5\%$ (greater of both). With SHB permitted: ± 50 ms or $\pm 0,5\%$ (greater of both).
SHB	Function enable: Yes/No
	Current Tap: 5 to 50% (step 1%)
	Reset Time: 0.00 to 300.00 (step 0.01 s)
	Block Threshold: 0,07 to 20,00 xIn (step 0,01 xIn)
	Activation level: 100%.
	Deactivation level: 95%.
49T	Timed deactivation
	Activation through configurable inputs
52	Maximum number of openings: 1 to 10.000 (step 1)
	Maximum accumulated amperes: 0 to 100.000 (M(A ²)) (step 1)
	Opening time: 0,02 to 30,00 s (step 0,01 s)
	Closing time: 0,02 to 30,00 s (step 0,01 s)
	Excessive repeated openings: 1 tot 10.000 (step 1)
	Repetitive openings/Time: 1 tot 300 min (step 1 min)
	Open circuit breaker activation threshold: 60 mA
Programmable logic control (PGC)	OR4, OR4_LATCH, OR4_PULSES, OR4_TIMERUP, OR4_PULSE, NOR4, NOR4_TIMERUP, NOR4_PULSE, NOR4_PULSES, AND4, AND4_PULSES, AND4_TIMERUP, AND4_PULSE, AND4_LATCH, NAND4, NAND4_TIMERUP, NAND4_PULSE
Trip output	24 Vdc; 135 mJ (activation of the striker or low powered coil)
Outputs	3 configurable outputs (output 1, output 2 en output 3) : 250 Vdc - 8 A 30 Vdc - 8 A
Inputs	3 inputs: they are activated by short-circuiting the terminals without external supply.
Frequency	50/60Hz
Current measurement	Fundamental values (DFT)
	Sampling: 16 samples/cycle
	$\pm 2\%$ in a band of $\pm 20\%$ the nominal current and $\pm 4\%$ or ± 5 mA in the rest of the band.

Events	1024 events
Disturbance Fault Recording (DFR)	20 fault reports, 16 events in each 10 disturbance records in COMTRADE format (50 cycles each)
Load Data Profiling (Current Demand)	Demand of current with the following characteristics: - Number of records: 168 - Recording mode circular - Sampling rate (interval): configurable through communication: 1 - 60 min - Record format : Date/Time IMAX (in interval) IMAX (actual) IA; IB; IC; IN
Communication	USB port: Modbus RTU RS485 rear port: Modbus RTU or DNP3.0 serial (*)
Auxiliary supply	24-230 Vac/Vdc +10/-20%.
Battery supply	With USB KITCOM adapter or standard powerbank Commissioning internal battery
Self-powering from current	Three phase self-powering level : $I > 75$ mA

Environmental conditions	Operating temperature : -40 to 70°C
	Humidity: 95%
Transformers	Power supply and measurement standards CTs /1
Mechanical features	Metallic box
	Panel Mounting
	Height x Width: 90 mm x 245 mm
	Depth: 139,4 mm
	Weight: 3 kg
	IP-54 panel mounted

5.2 Thermal resistance

- 4xIn continuously.
- 30 x In for 10 seconds.
- 100 x In for 1 second.
- Short-circuit: 20 kA during 200 ms

For model RP-800xxxxxxxxxU (with UL-certification) the thermal resistance is :

- 3xIn continuously.
- 30 x In for 10 seconds.
- 100 x In for 1 second.
- Short-circuit: 20 kA during 200 ms

6 COMMUNICATION AND HMI

6.1 Front Communication: USB

One communication port is installed on the front of the relay. The connector that is used is a micro USB. The protocol that is used is Modbus RTU (19200 -8bit – no parity – 1 stop bit). The protocol map and documentation that are used are attached in an appendix to this manual.

To write commands it is necessary to set up a communication session (identification command) which it will be closed after a period of time without communication. To set up a communication session it will be necessary a password. To write commands the password will be adjuSetting group.

6.2 Rear Communication: RS485

The RS485 port output has two terminals (+, -), located on the rear of the relay. The protocol that is used is Modbus RTU or DNP3.0 Serial (19200 -8bit – no parity – 1 stop bit).

This port can be used to continuously monitor the relay from a remote PC or SCADA system. Up to 32 pieces of relay can be connected to one bus; each piece with a different Modbus address. The relay Modbus address can be configured using the SCom program.

To minimize communication errors because of noise, the use of a stranded and shielded cable is recommended for the physical connection. All the + terminals on

one side, and all the - terminals on the other must be connected together in order to make the connection.

Resistors should be used at each end if very long cables are used. The best solution for avoiding reflection is to install resistors at both ends of the cable. The ohm value of these resistors must be equal to the cable impedance value.

Fiber optics can be used in very aggressive environments, and they are connected by using the corresponding converters.

Connection diagram for a RS485 bus :

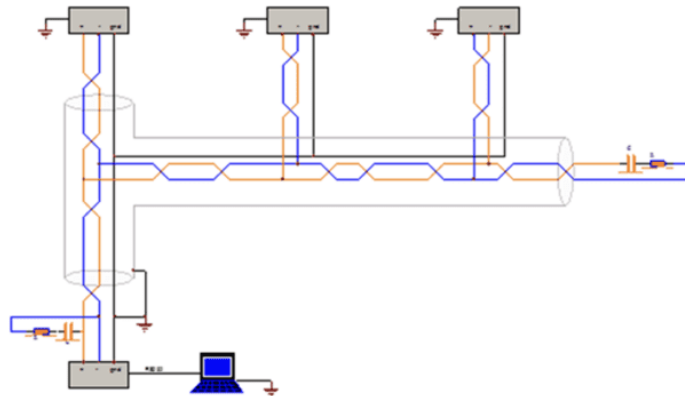

Minimum required current to achieve remote communication: 360 mA (single phase), 180 mA (2-phase) and 120 mA (3-phase).



NOTE: When the relay is communicating remotely if any button of the HMI is pressed, the relay will automatically switch to local control. If this happens, the relay will enable to read any value but it will not be possible to change/write settings or configuration.

6.3 LED indicators

The SIA-B front panel is provided with 4 configurable LED pilot that by default show:

LEDS	Default configuration
Led 1	Ready
Led 2	Neutral / Earth fault trip
Led 3	Overcurrent trip
Led 4	Thermal trip

Few situations can occur that involve the activation of different LEDs, this is, it can be more than one led activated at the same moment. It is possible to verify the correct running of the LEDs via test menu.

6.4 LCD and keypad

The front of the SIA-B relay is fitted with an alphanumeric LCD screen, measuring 20x2. This screen provides the user with access to read information about the

settings parameters, measurements, state and events. The whole information is organized in a system of menus.

A keypad is fitted to the relay front panel, which can be used to access the information shown on the LCD screen and to navigate through the menu system.

This keyboard is provided with 6 keys that can be used to navigate through the different menus and to change the setting parameters. The ▲ ▼ and ◀ ▶ keys can be used to navigate through the different menus, the different options in each menu and the different values for the settings parameters.

The “OK” key is used to access the menus and the different options, as well as to approve changes to values. The “C” key is used to delete and to go back through the menu levels.

As well as the 6 keys, there is also a “Reset” key. When “Reset” is pressed, leds and outputs are reset (if they are activated and the reason of their activation is clear) and the key can also be used to delete all of the events from the “Events” menu and fault reports, from “Faults” menu.

6.5 SICom Communications program

The SICom program works with the Windows®, Windows 7, Windows 8 and Windows 10 operative systems.

The following operations can be carried out using the SICom program:

- Status reading
- Measurement reading
- Reading and changing settings
- Reading and changing configuration
- Reading and deleting events
- Reading and deleting DFR's (fault reports and COMTRADE files)
- Changing the user passwords
- Loading settings files
- Loading configuration files
- Date-time synchronization
- Checking the versions of the relay
- Configuring the communication parameters
- Configuring and checking load data profiling

6.5.1 How to install the SICOM software



6.6 Setting-up the session: Password and access levels

The relay is provided with different passwords associated to access levels allowing the user to carry out different actions depending on the selected password:

Access level	Read-only Function enable : Status and measurements Settings Configuration Events/RDF	Function enable to: Change settings	Change settings Function enable to : Delete events Delete DFR	Function enable to : Execute Commands	Function enable to: Change configuration Change protected settings
2	Yes	Yes	Yes	No	No
3	Yes	No	No	Yes	No
4	Yes	Yes	Yes	No	No
5	Yes	Yes	Yes	Yes	Yes

Four passwords and their associated levels of access are set up when the relay is configured using the SICom-program. The password must be made up of 4 characters (passwords with more or less characters will not be accepted). By default, the relay is programmed with the following passwords and their associated levels:

Password	Access level
2222	2
3333	3
4444	4
5555	5

6.7 MENUS

6.7.1 Standby mode screen

The default screen shows the device model and the currents in phase A, phase B, phase C and Neutral. Press 'OK' to select a menu : measurements, states, settings and events. If the HMI is left in any state, it will return to the default screen after 5 minutes without any key being pressed.

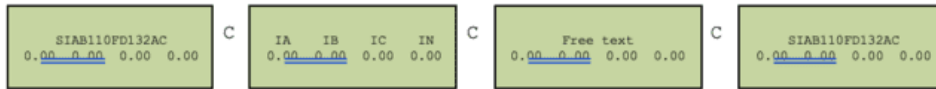

6.7.2 Accessing the menus

The keys ▲, ▼, ◀ and ▶ are used to navigate through the different options and menus. The “OK” key is used to accept and to enter a menu or an option. The “C” key is used to move up through the menu levels.

It is not necessary to enter any password to read or view the parameters, measurements or settings...

A 4-character password must be entered in order to modify any parameter.

After returning to the main screen, the password must be entered again to make any further modifications.

The keys ◀ and ▶ are used to navigate from one item to another within a parameter. The keys ▲ and ▼ are used to increase or decrease the value. If an invalid value is entered during the process, the “C” key can be used to delete it.

The navigation through the menus is described as graphically as possible below.

6.7.3 Date-time menu

The date-time menu can be accessed by pressing the “▶” key from the standby mode screen. From here, press the “OK” key to access the date-time modification screen. Use the “▶” and “◀” keys to position the cursor over the digit that you want to change and assign a value to this digit using the “▲” and “▼” keys. Once the date-time has been entered, press “OK” to change the relay date. Press the “C” key to return to the standby mode screen.

The date-time information can be viewed by pressing the “▶” key from the main screen.

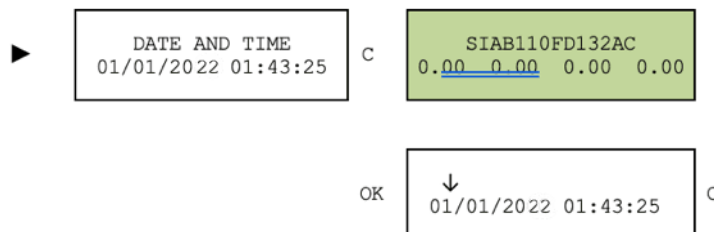

6.7.4 Versions

The relay versions menu can be accessed from the standby mode screen by pressing the key "▲". This displays the software versions of the relay processors. Press the "C" key to return to the standby mode screen.

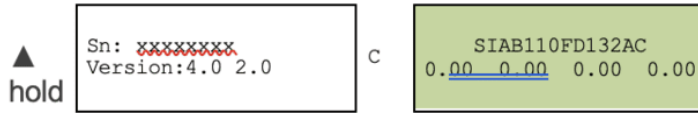

6.7.5 Communication parameters

The Communications parameters can be viewed holding down the "▼" key from the standby mode screen.



6.7.6 Contrast

The contrast menu can be accessed from the standby mode screen by pressing the "◀" key.

Contrast level can be changed using the "▲" and "▼".

Press the "C" key to return to the standby mode screen.



6.7.7 Fault report

From the sleep mode screen, press the "◀" key to access the fault report. Use the "▲" and "▼" keys to find the fault report and "OK" the data of this fault report can be read.

- In case the buffer is empty:

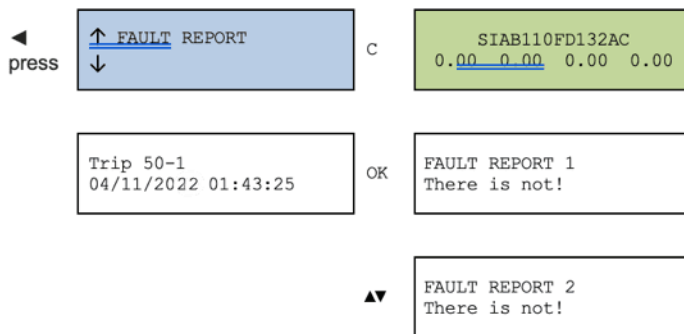

- In case there are fault reports recorded:

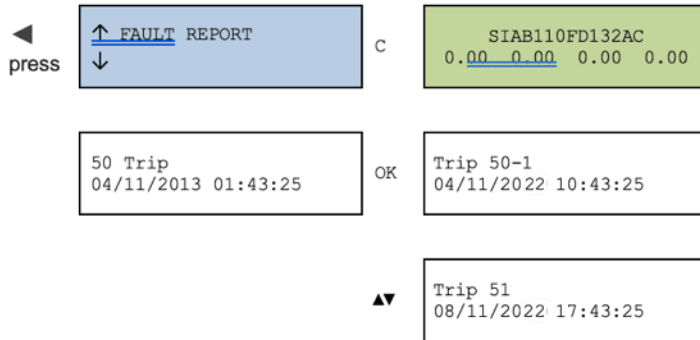

The name of the fault reports indicates the function that has tripped and originated the fault report.

6.7.8 TestMenu

The "Test menu" is accessed from the standby mode screen by sequentially pressing the "◀", "▼" and "▶" keys, and then holding down the "OK" key. From here, press "OK" to access the components that can be tested.

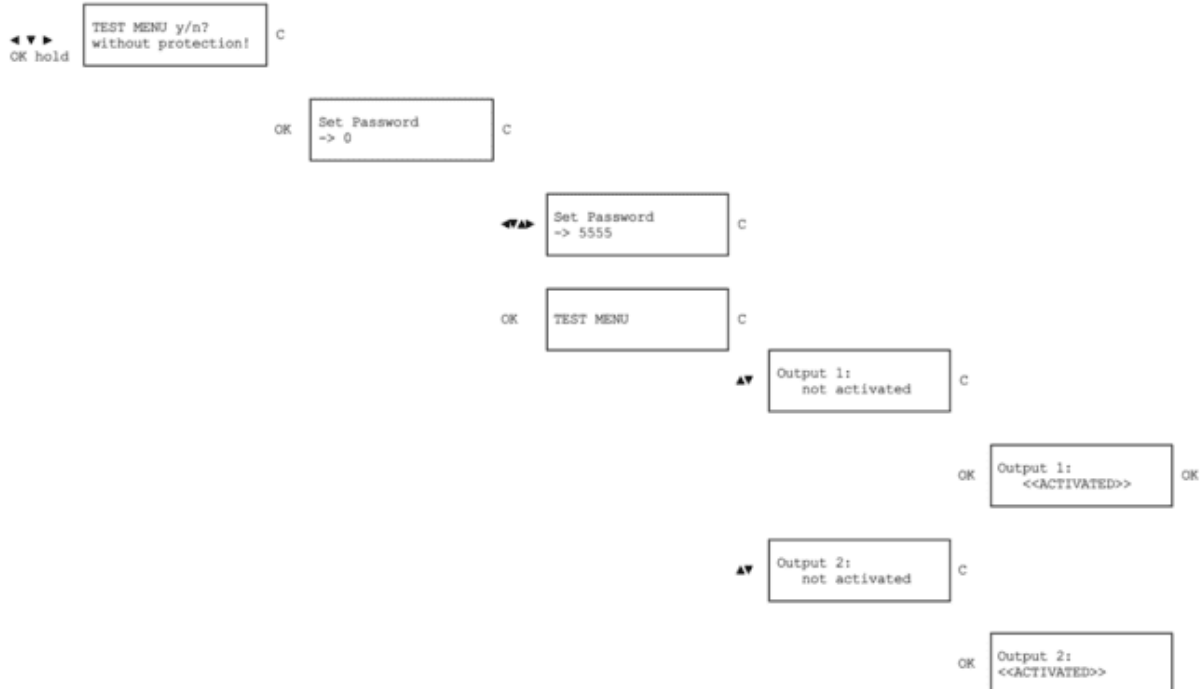

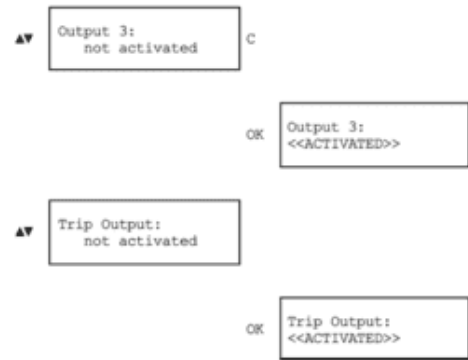

6.7.9 Functions Menu

The SIA-B relay menu is split up into 8 main parts:

- Measurements.
- States.
- Settings.
- Events.
- Counters.
- Commands.
- LDP (load data profiling – current demand).
- Fault reports.

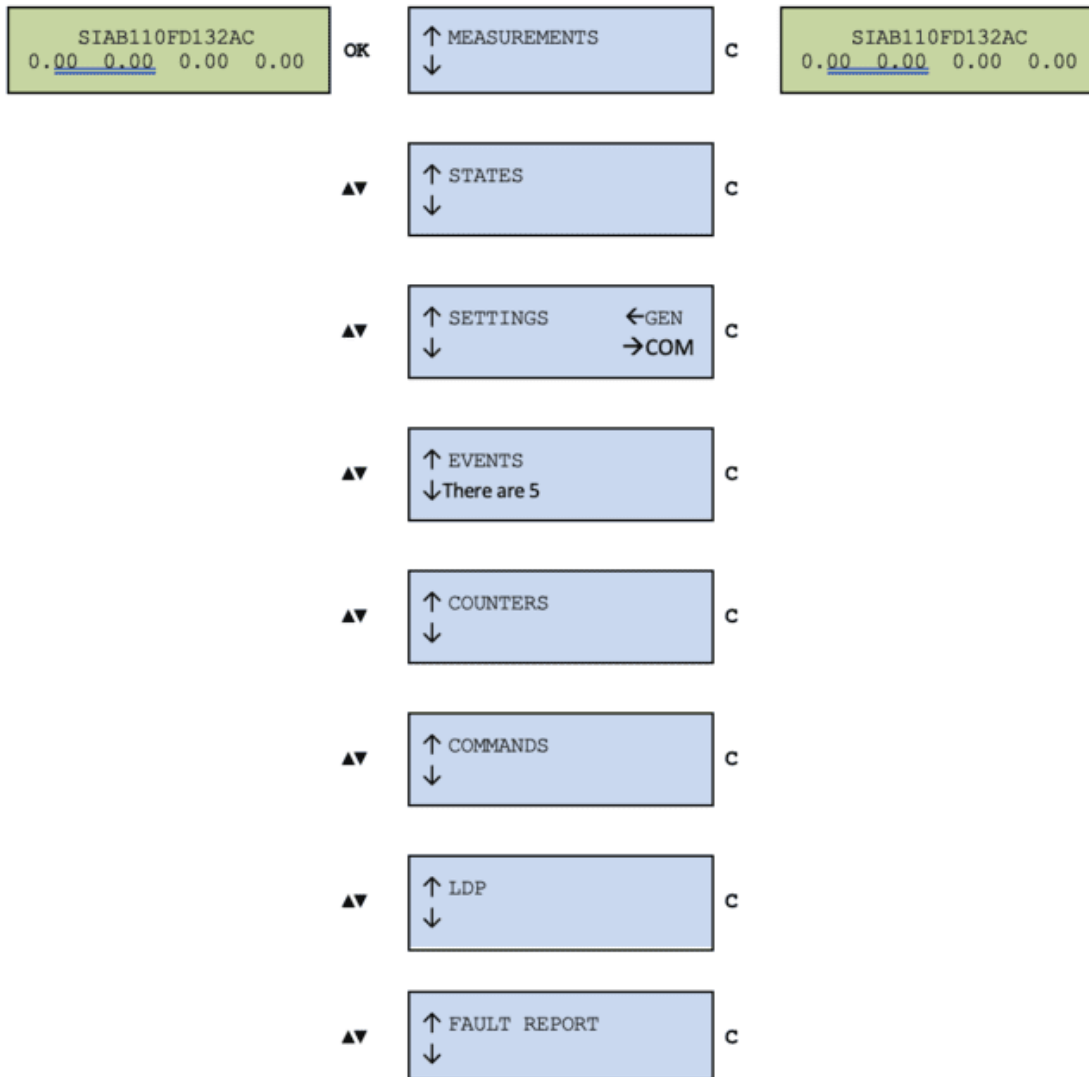

Press the "OK" key to access the second level from the main screen. Use the ▲ and ▼ keys to move from one menu section to another in the second level. Use the "C" key to return to a higher level.

6.7.10 Measurements Menu

From the standby mode screen, press the "OK" key to access the First line of menus. Use the "▲" and "▼" keys to position the cursor over the "MEASUREMENTS" screen and press "OK". Use the "▲" and "▼" keys to position the cursor over the measurement and to see its value.

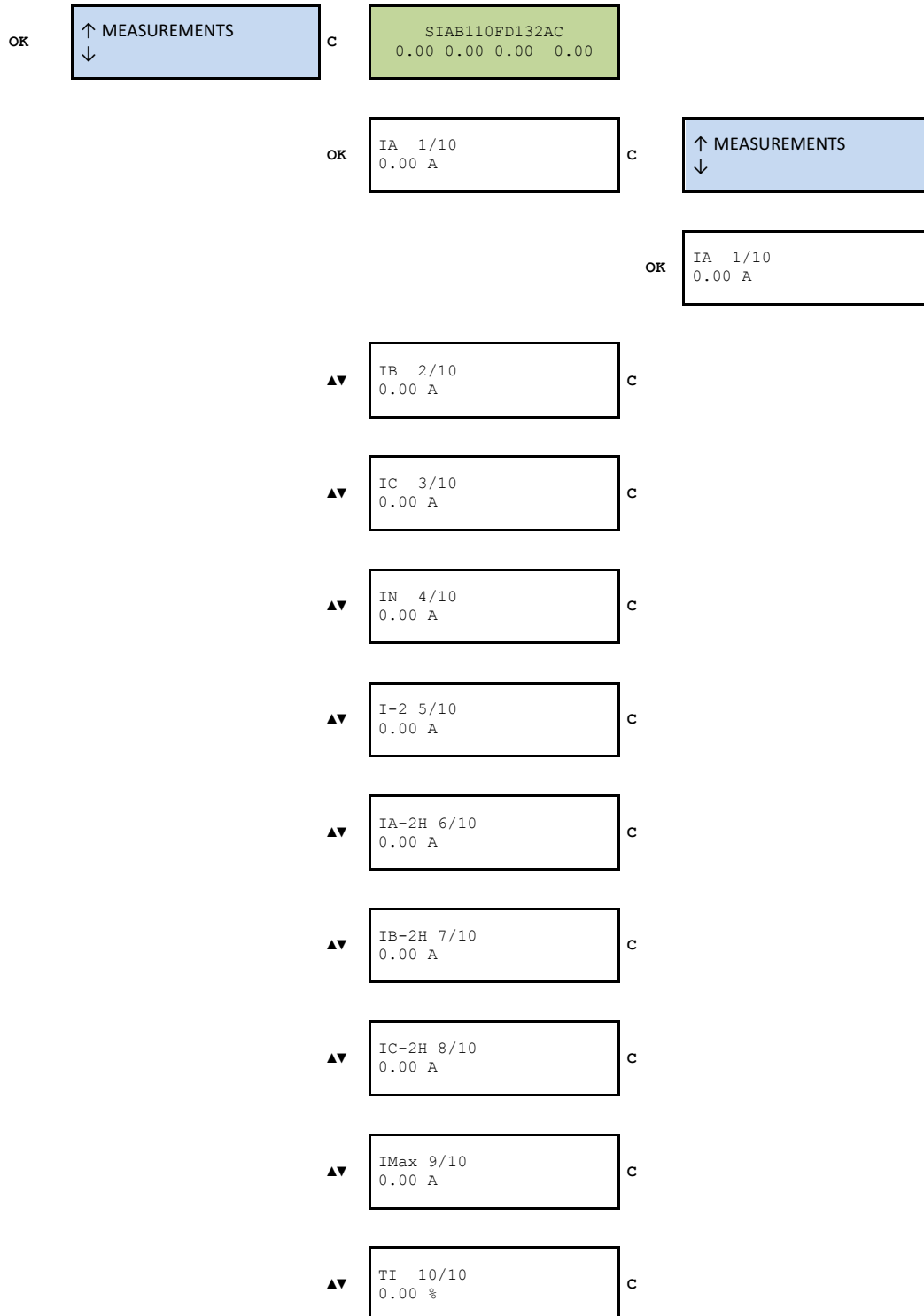

6.7.11 States menu

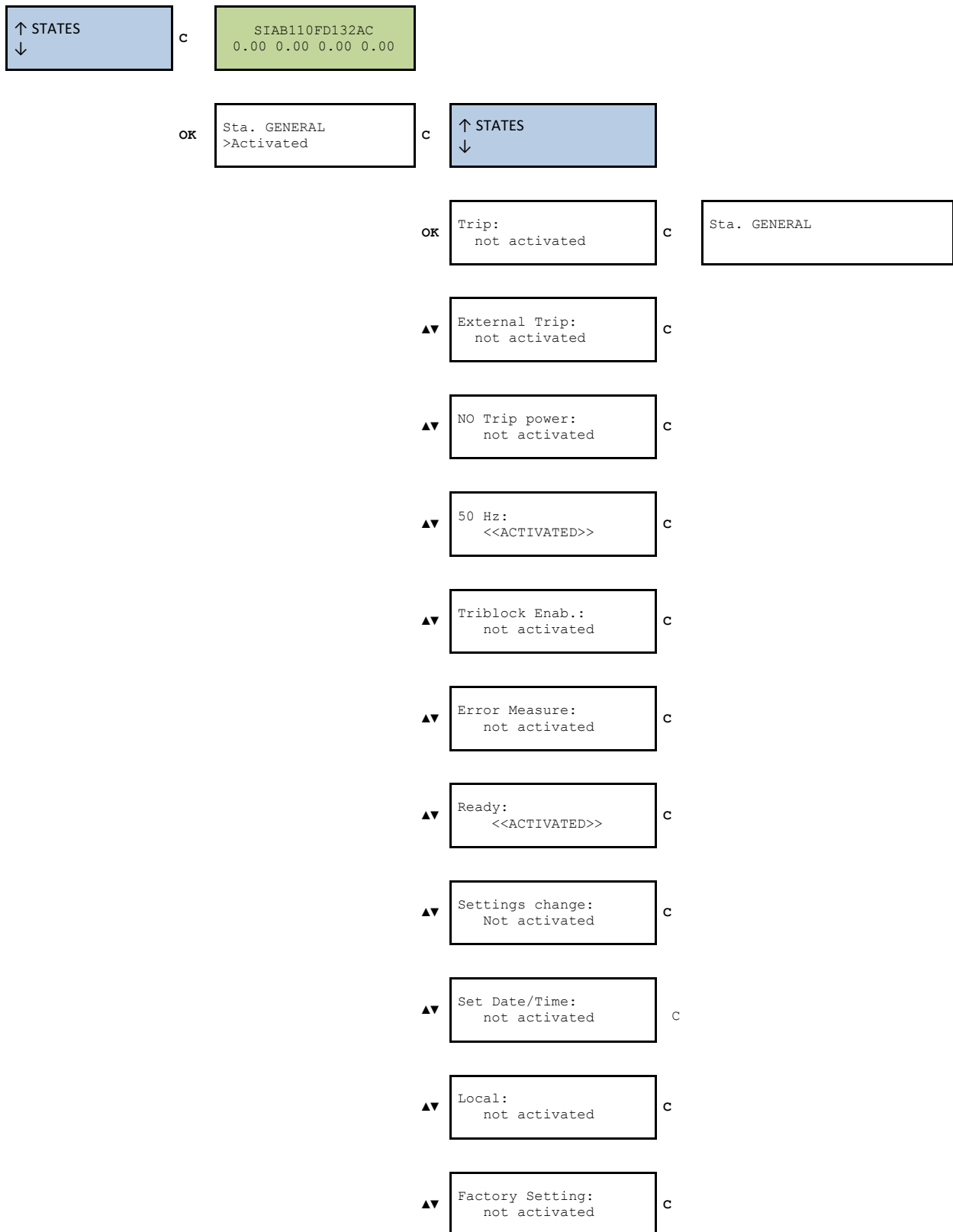

- ▲▼ Error Eeprom:
not activated c
 - ▲▼ Eeprom changed:
not activated c
 - ▲▼ Error Event:
not activated c
 - ▲▼ Pickup:
not activated c
 - ▲▼ Phase A Pickup:
not activated c
 - ▲▼ Phase B Pickup:
not activated c
 - ▲▼ Phase C Pickup:
not activated c
 - ▲▼ Ground Pickup:
not activated c
 - ▲▼ Phase A Trip:
not activated c
 - ▲▼ Phase B Trip:
not activated c
 - ▲▼ Phase C Trip:
not activated c
 - ▲▼ Ground Trip:
not activated c
 - ▲▼ 50 Trip:
not activated c
 - ▲▼ 50G Trip:
not activated c
-

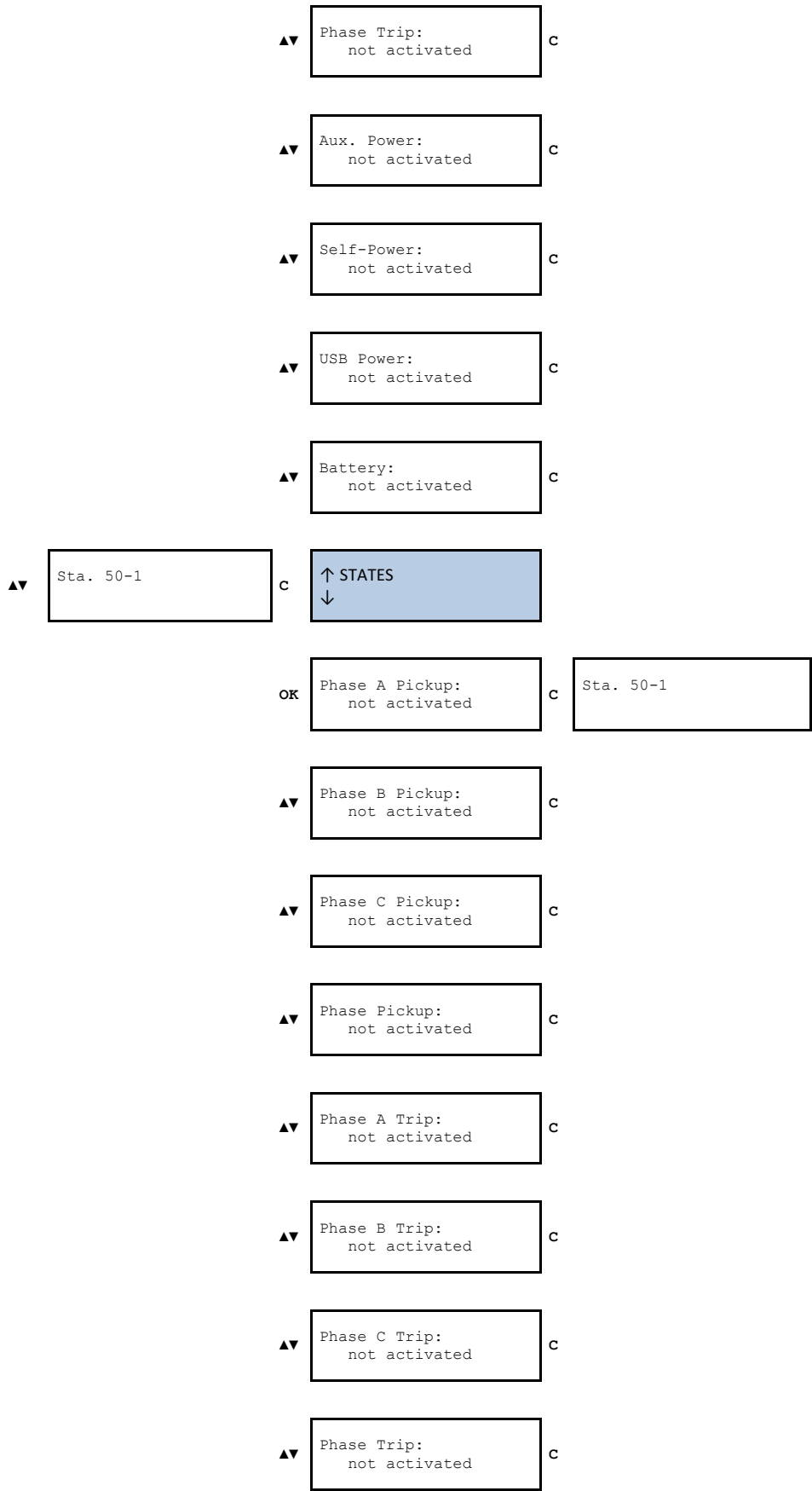

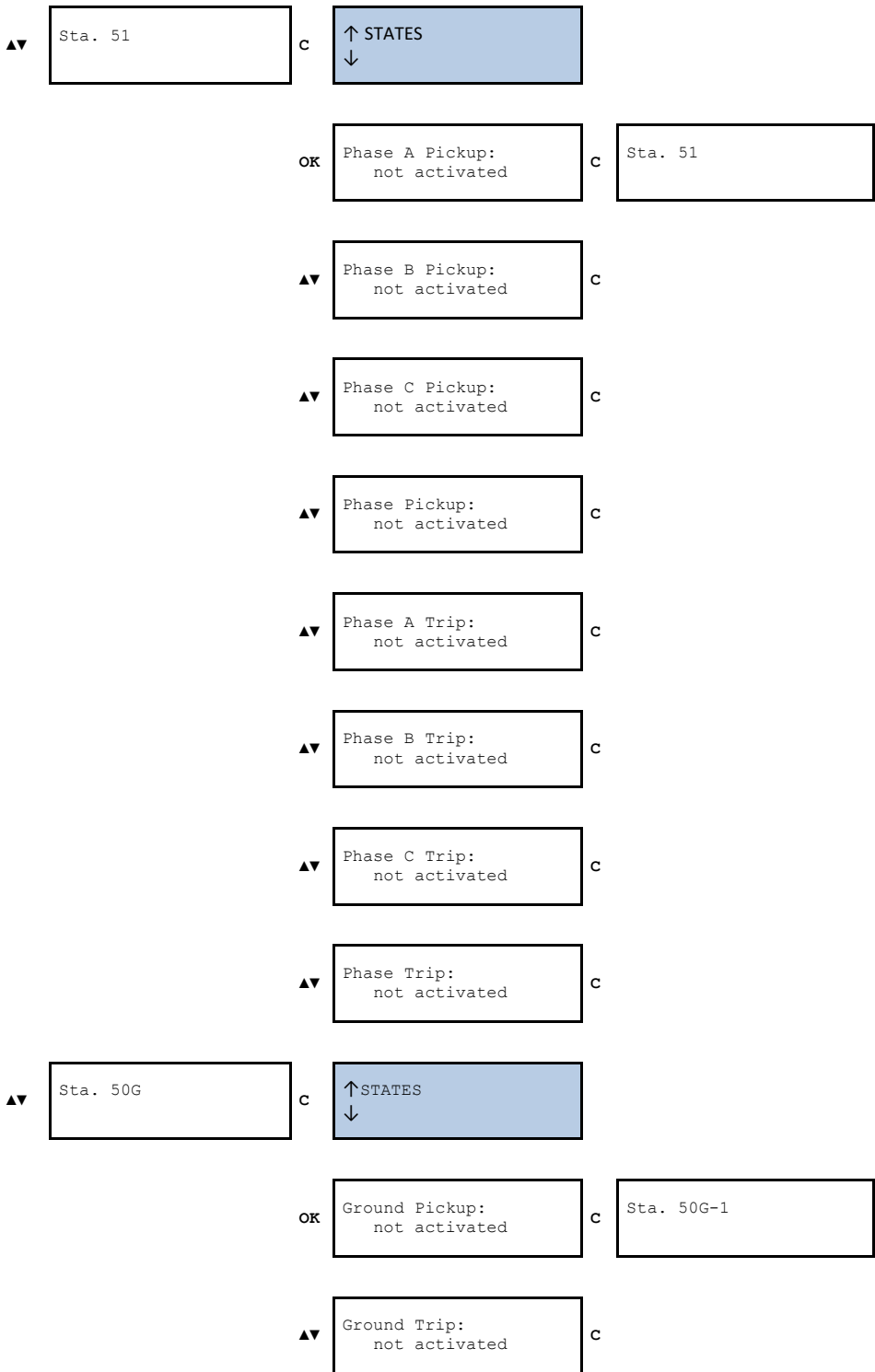

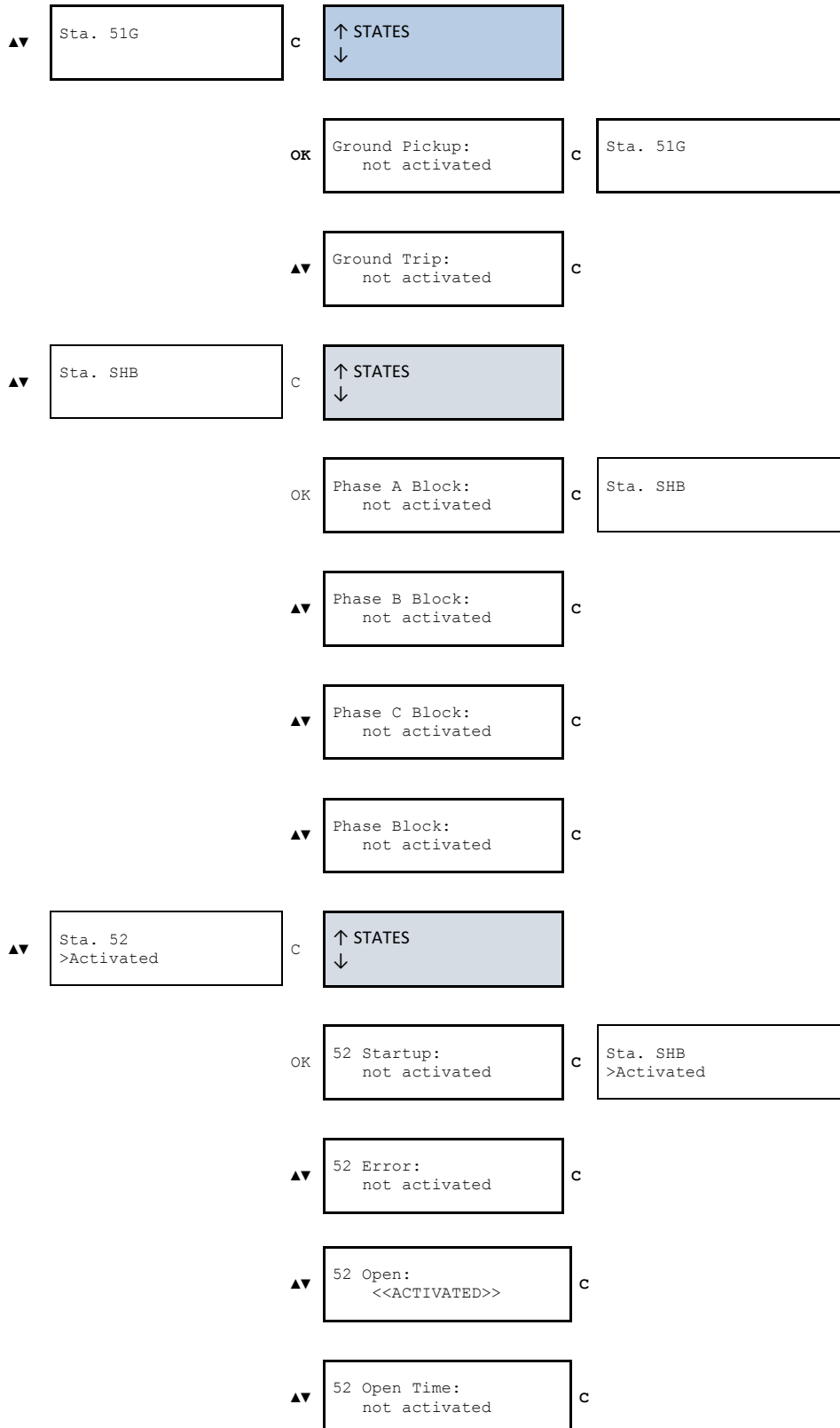

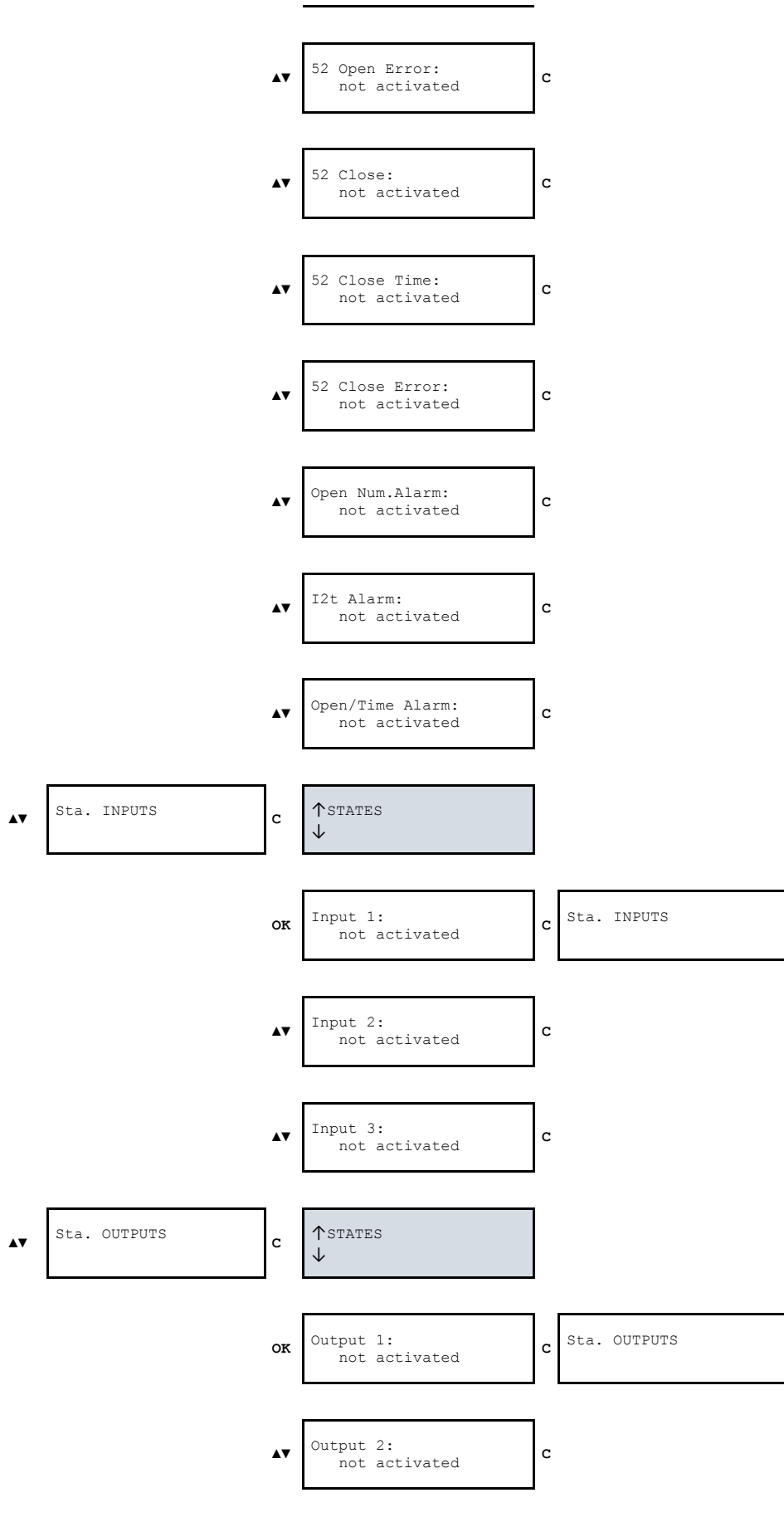

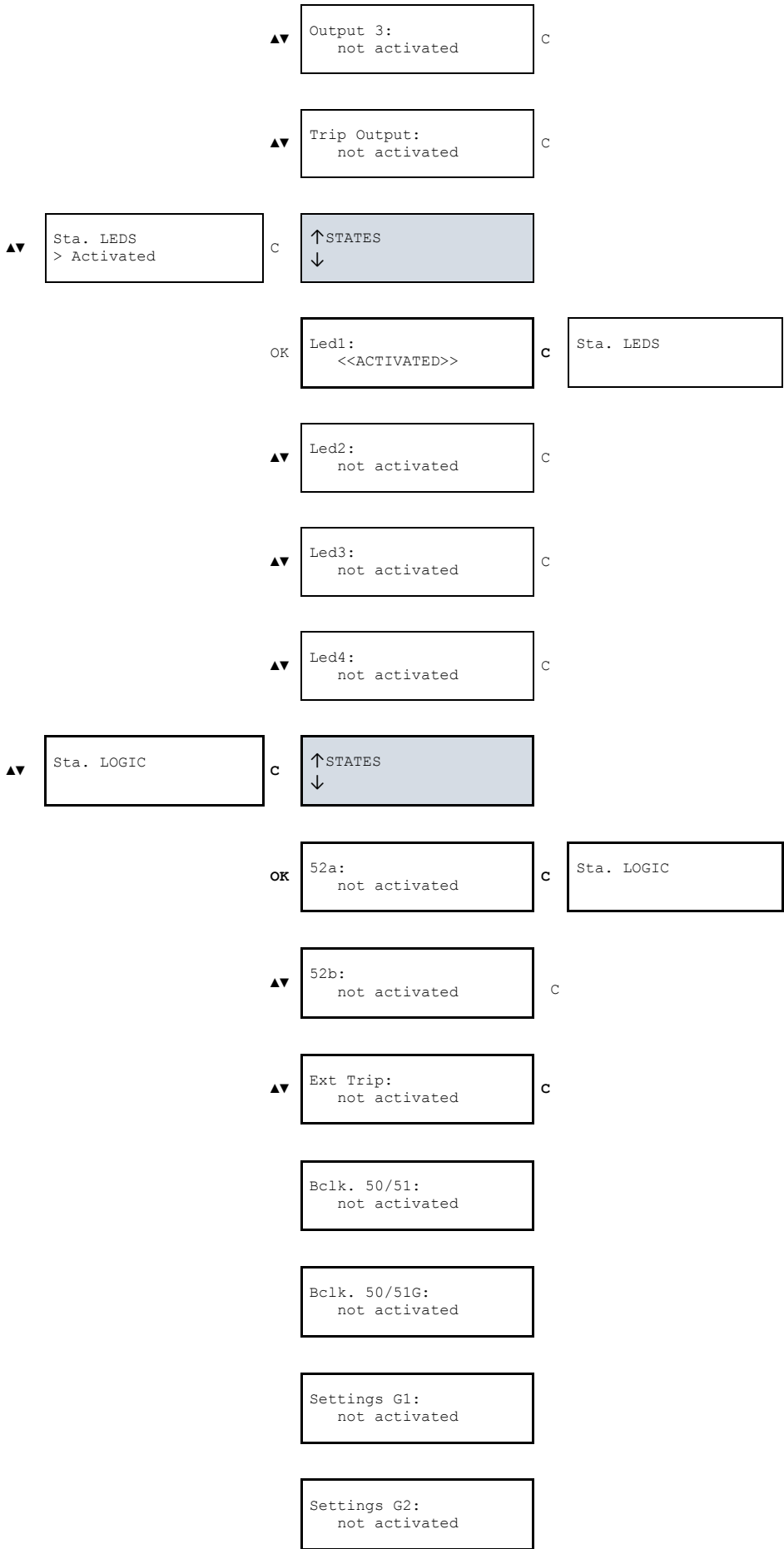

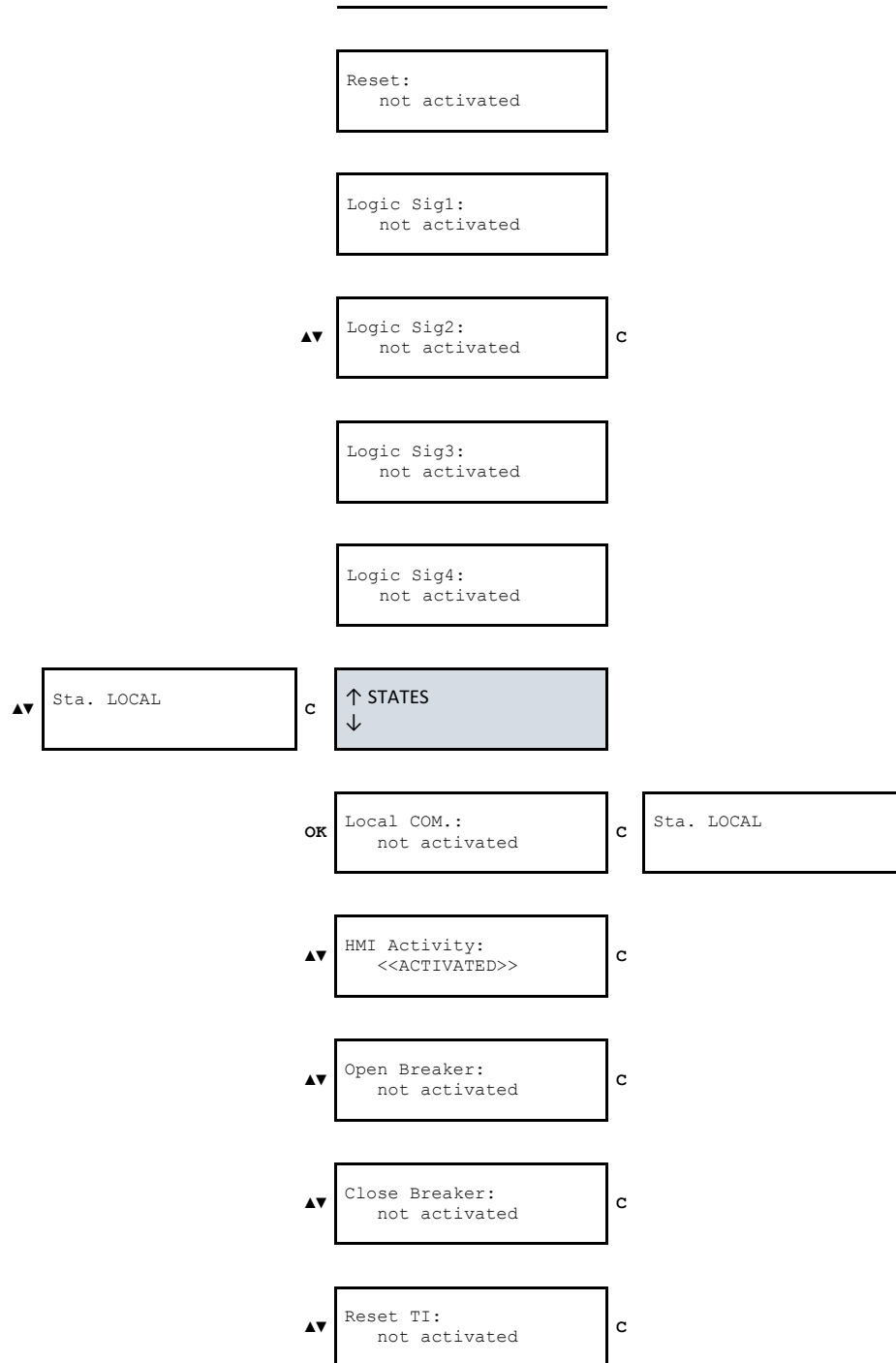

Remote communication depends on the selected setting in general settings:

- Internal communication: MODBUS RTU :

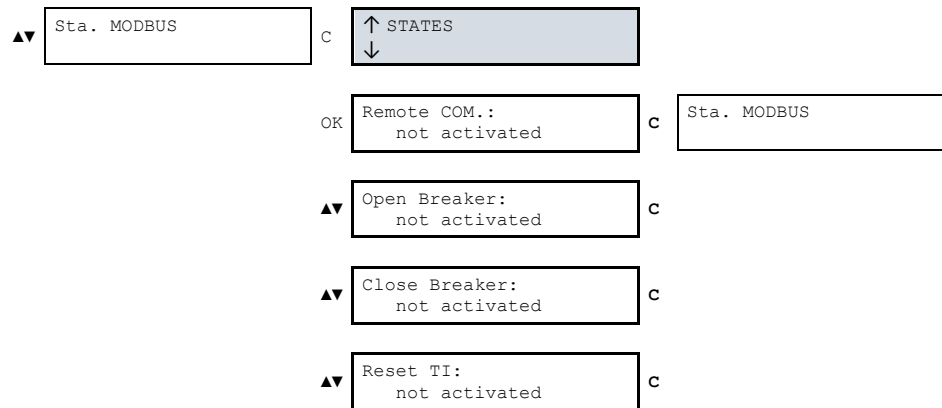

- External communication: DNP3.0 Serieel :

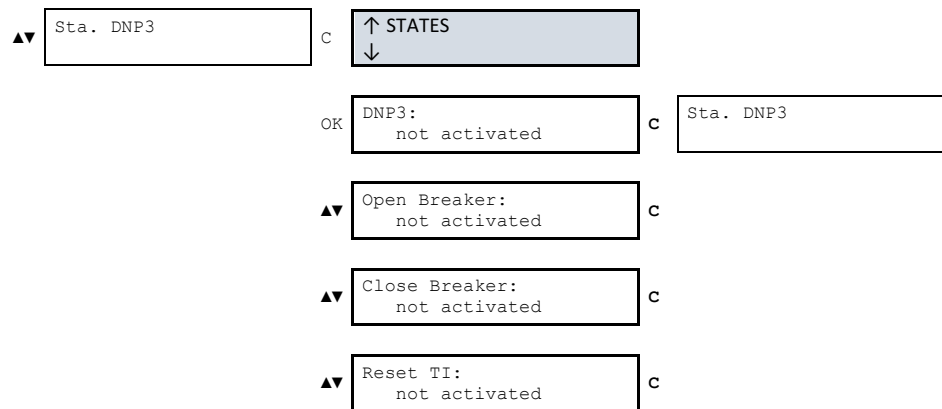

6.7.12 Settings Menu

From the standby mode screen, press the “OK” key to access the first line of menus. Use the “▲” and “▼” keys to position the cursor over the “SETTINGS” screen and press “OK”. This takes you to the setting groups’ line. Use the “▲” and “▼” keys to position the cursor over a settings group, and press the “OK” key to access the settings that belong to this group. Use the “▲” and “▼” keys to move through the different settings. The information that appears underneath the setting name is its value.

Press the “◀” key to access the general settings from the “SETTINGS” screen.

The value of the “CT Phase ratio” and “CT Neutral ratio” general settings is the result given by dividing the number of turns on the primary winding by the number on the secondary winding. For example: With TI 100/1, the setting would be 100.

It is necessary to enter a password to change a setting for the first time. The settings can be changed after entering the password, until returning either manually or automatically to the standby mode screen. The system returns automatically to the standby mode screen if no key is pressed for five minutes.

The factory setting password for the relay is 5555. This password can be changed using the SICom program.

The keys ▲, ▼, ◀ and ▶ are used to enter the password. The keys ▲ and ▼ are used to introduce a value or a character, and the ◀ and ▶ ones are used to move from one character to another. If it is necessary to change one of the password characters or numbers due to an error, press “C” to delete it. Press “OK” to validate the password.

The method for navigating through the settings menu and the sequence to follow to change a setting are shown graphically below:

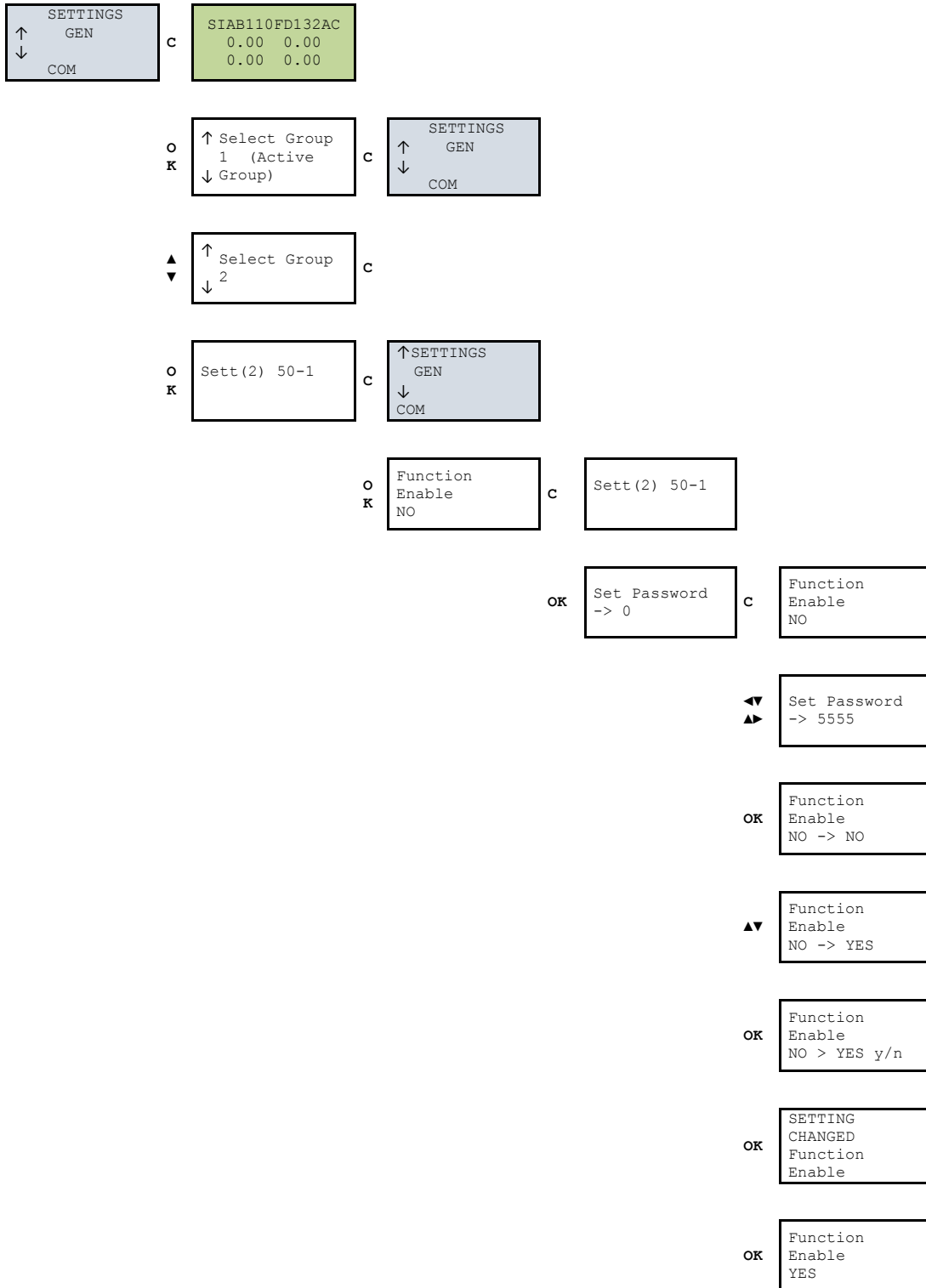

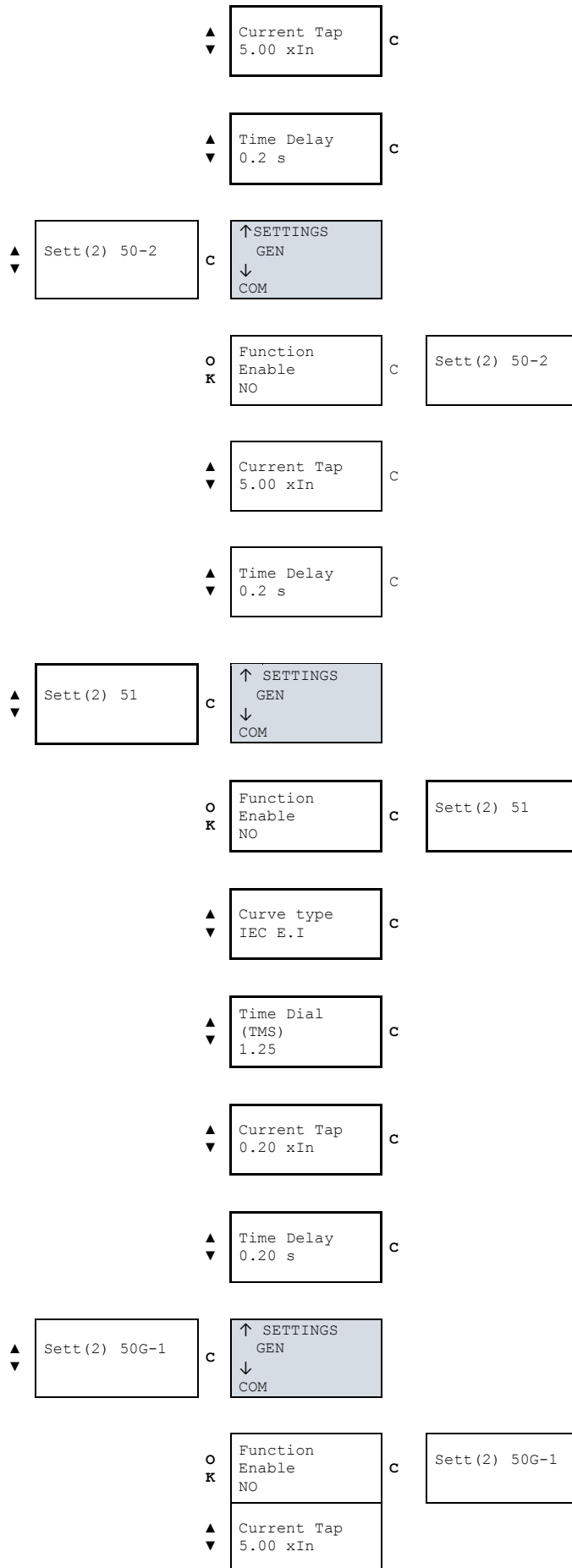

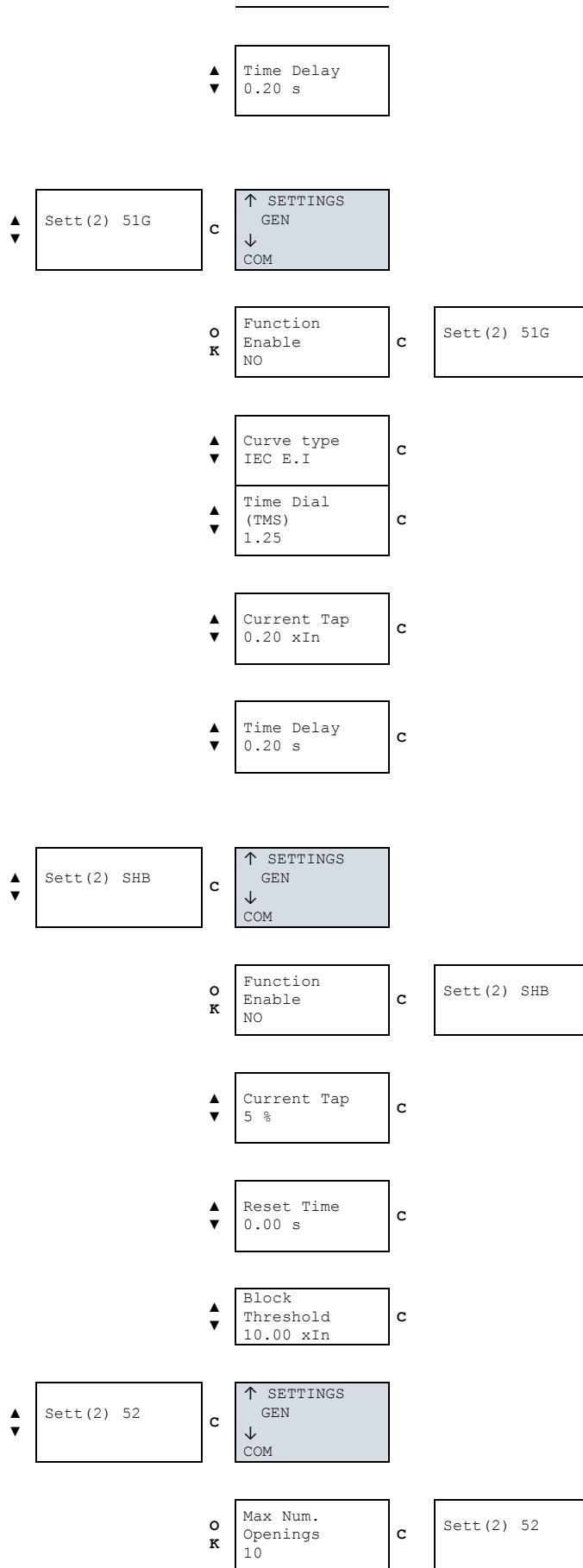

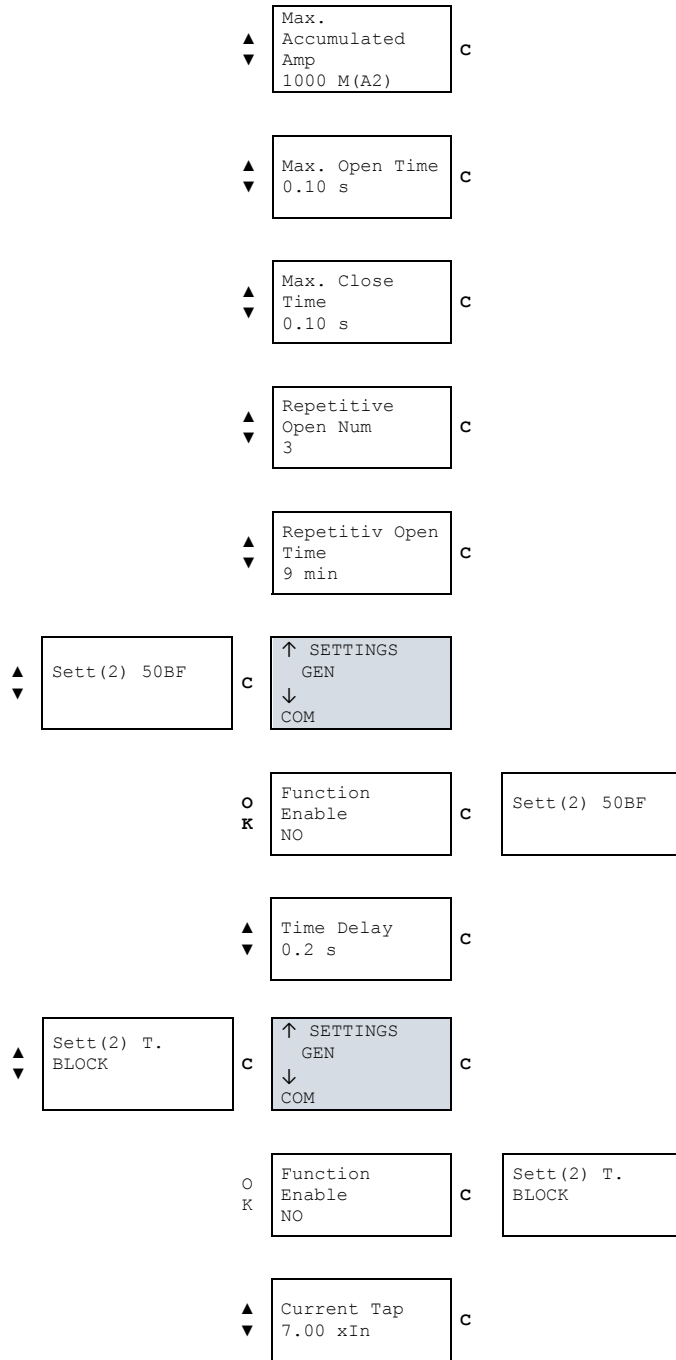

To access the general settings from the "SETTINGS" menus, press "◀"

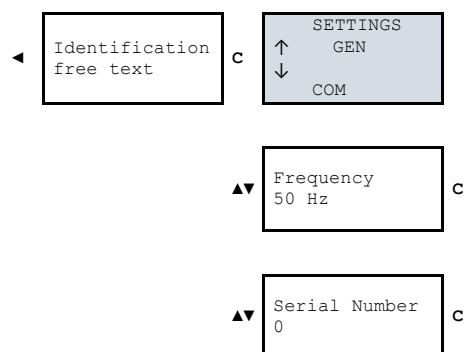

▲▼	Language ENG.	c
▲▼	Active Settings G. 1	c
▲▼	Trip Vol. Level 17 Vdc	c
▲▼	CT Phase Ratio 1.0	c
▲▼	CT Neutral Ratio 1.0	c
▲▼	Local COM Address 1	c
▲▼	Remote Address 2	c
▲▼	Remote BaudRate 19200	c
▲▼	Remote Protocol (**)	c

(**) Depending on the selected remote communication: MODBUS:

▲▼	Remote BaudRate 19200	c
▲▼	Remote Protocol MODBUS	c

- DNP3:

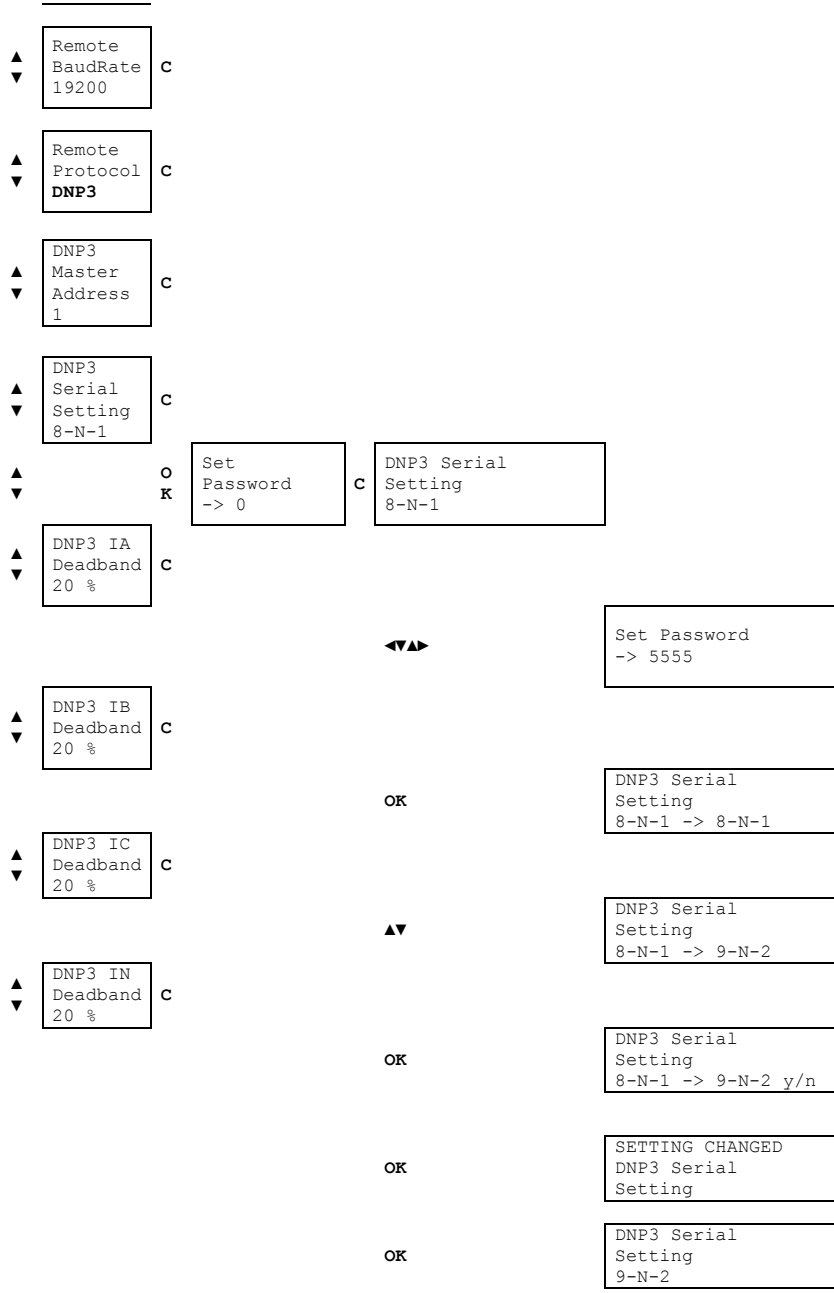

6.7.13 Events Menu

From the standby mode screen, press the "OK" key to access the First line of menus. Use the "▲" and "▼" keys to position the cursor over the "EVENTS" screen and the number of events in the buffer will be displayed. Press "OK" and use the "▲" and "▼" keys to position the cursor over the events.

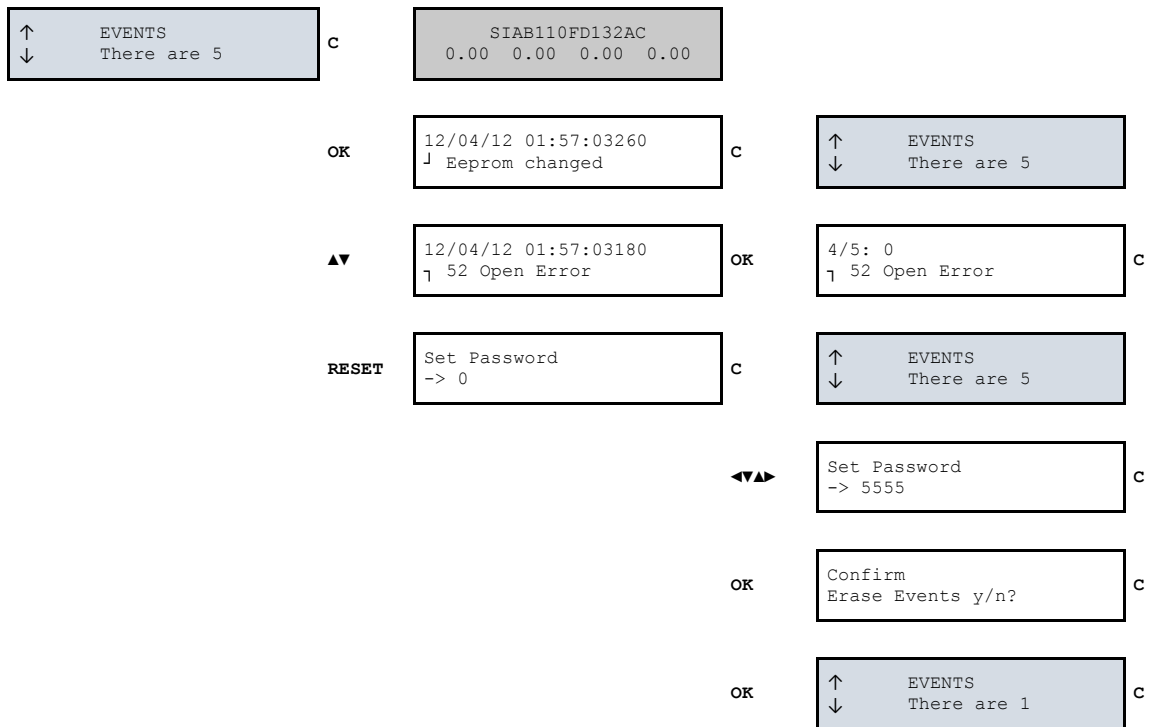

The "┘" and "└" shows the event has been caused by the activation or reset of the associated state.

To delete the events buffer, position the cursor over the events menu and press 'RESET' key, until there is only one event shown. This one event is "Deleted events".

Each event contains the following information:

- Date-time
- Description of the event
- Size of the events buffer
- Position of the event within the list of events
- Events generated by a state activation or reset
- Associated measurement (i fit has one)

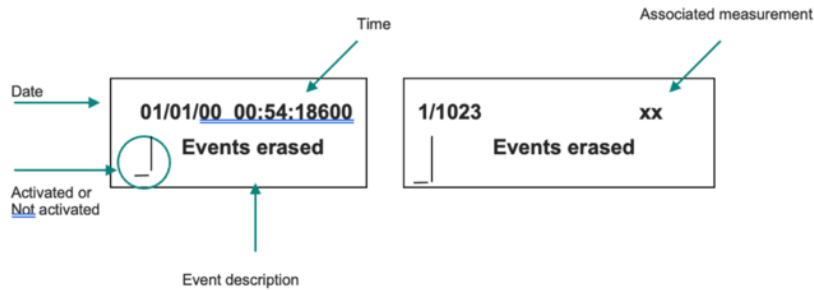

6.7.14 Counters Menu

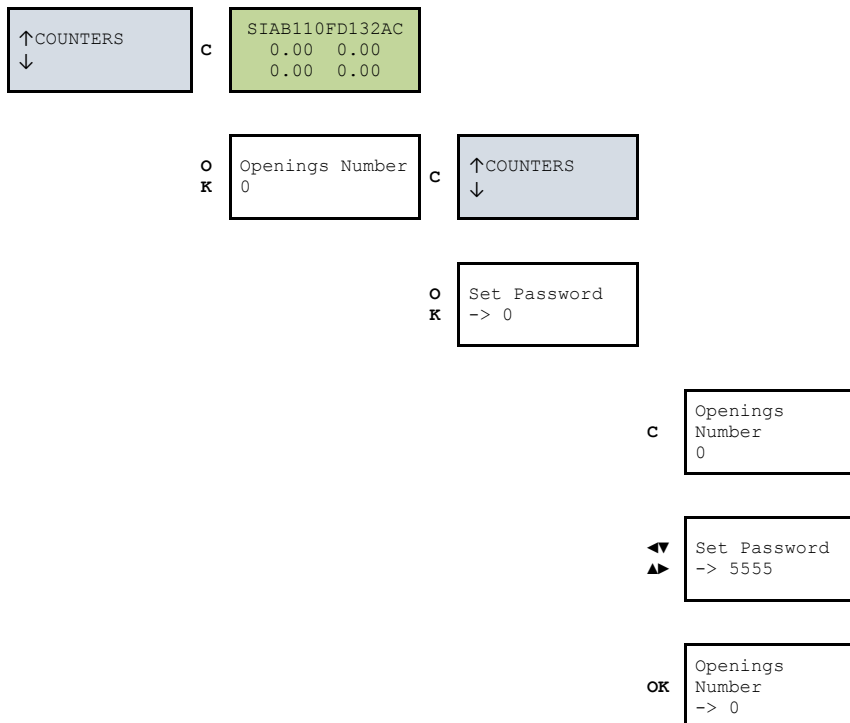

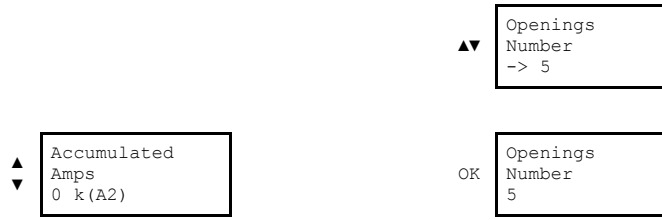

6.7.15 Commands Menu

The First line of menus can be accessed from the standbymode screen by pressing the "OK" key. Use the "▲" and "▼" keys to move the cursor through the different screens until it is positioned over the "COMMANDS" screen. Press "OK" and use the "▲" and "▼" keys to view the different possible commands. Press the "OK" key to perform a command and press the "OK" key again to confirm the command.

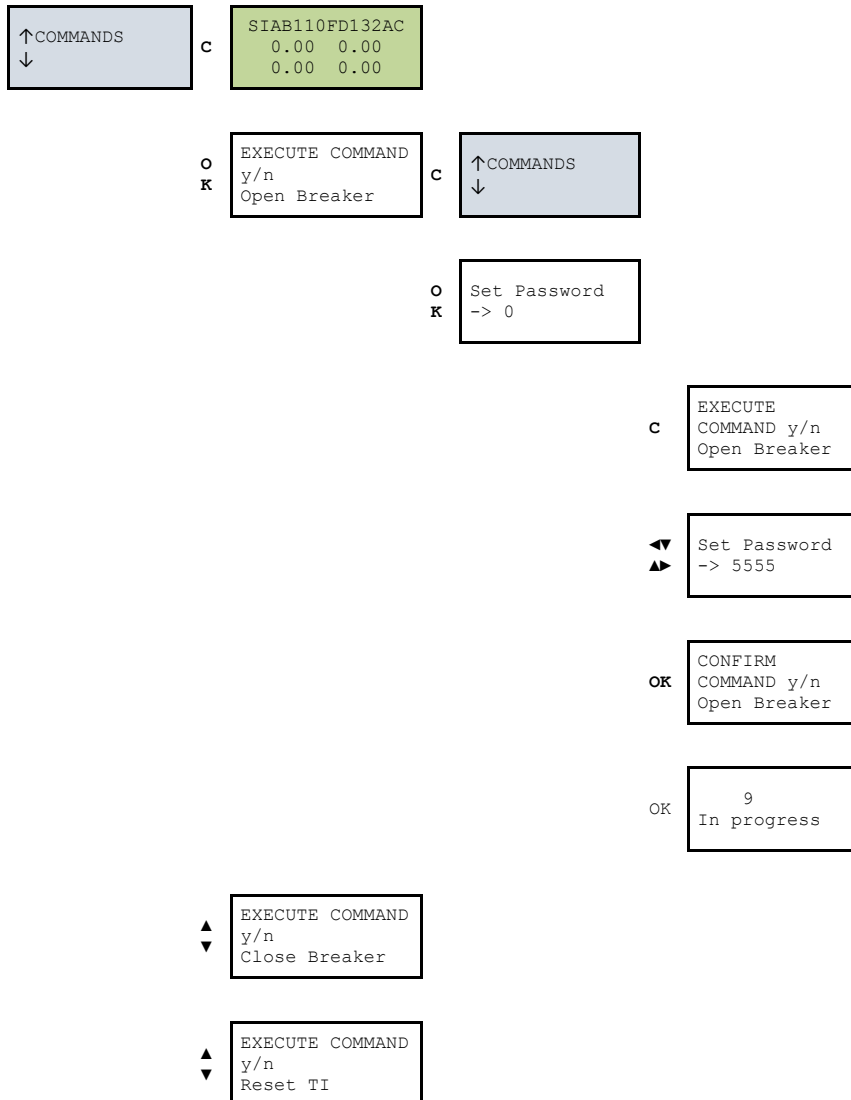

6.7.16 Load Data Profiling

From the standby mode screen, press the "OK" key to access the first line of menus. Use the "▲" and "▼" keys to position the cursor over the "FAULT REPORT" screen. Press "OK" and use the "▲" and "▼" keys to position the cursor over the Fault Report. It is also possible to access Fault Report menu pressing "◀" key from standby screen.

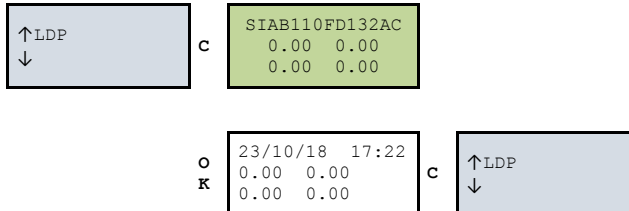

6.7.17 Fault Reports

From the standby mode screen, press the "OK" key to access the first line of menus. Use the "▲" and "▼" keys to position the cursor over the "FAULT REPORT" screen. Press "OK" and use the "▲" and "▼" keys to position the cursor over the Fault Report. It is also possible to access Fault Report menu pressing "◀" key from standby screen.

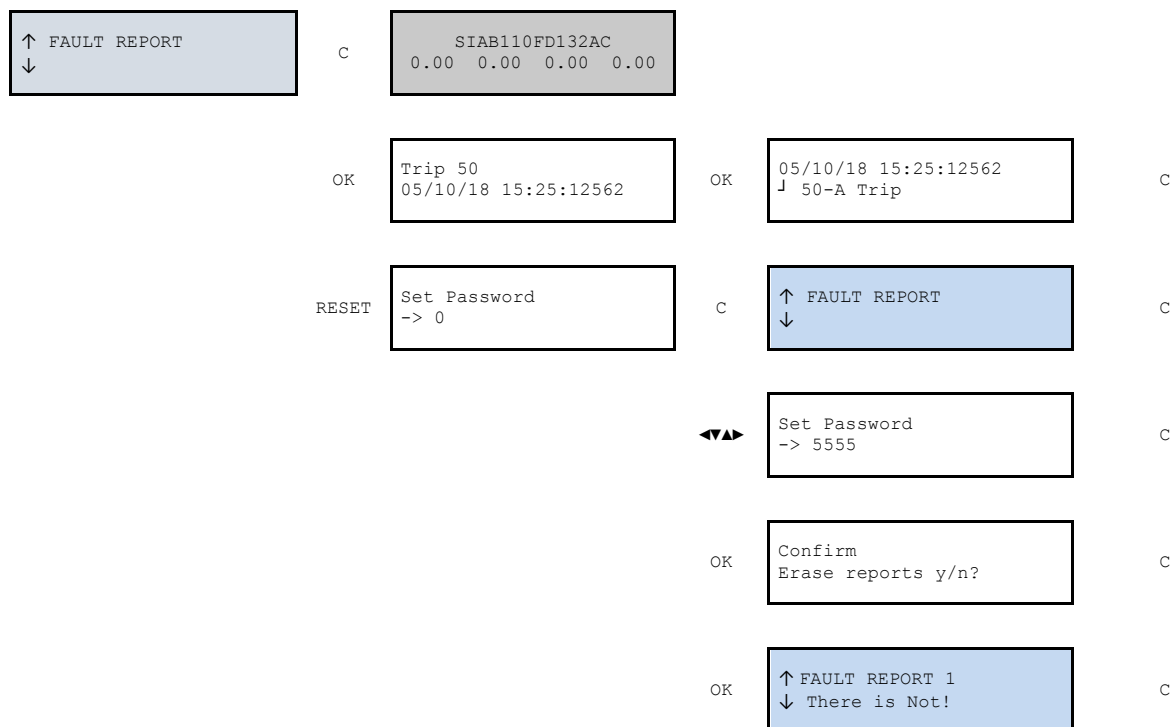

To delete the fault reports, position the cursor over the fault report menu and press and hold the "RESET" key, until password is requested. Introduce the password and press OK until there is a message informing "fault reports erased".

6.7.18 PGC and Outputs Configuration Menu

To assign an instantaneous state to a physical output, browse through the STATE menu to find the desired instantaneous state. When the state appears, press ► to enter the output configuration menu. Use the "▲" and "▼" keys in this menu to find the desired physical output. Then it is necessary to assign the logical gate. To do it, it is necessary to press ◀. Finally, it is necessary to confirm the choice by pressing "OK". After, the confirmation is displayed on the screen; the index of 1 to 4 associated to the instantaneous state within the physical output configuration is displayed. Go up through the menu levels by pressing the "C" key.

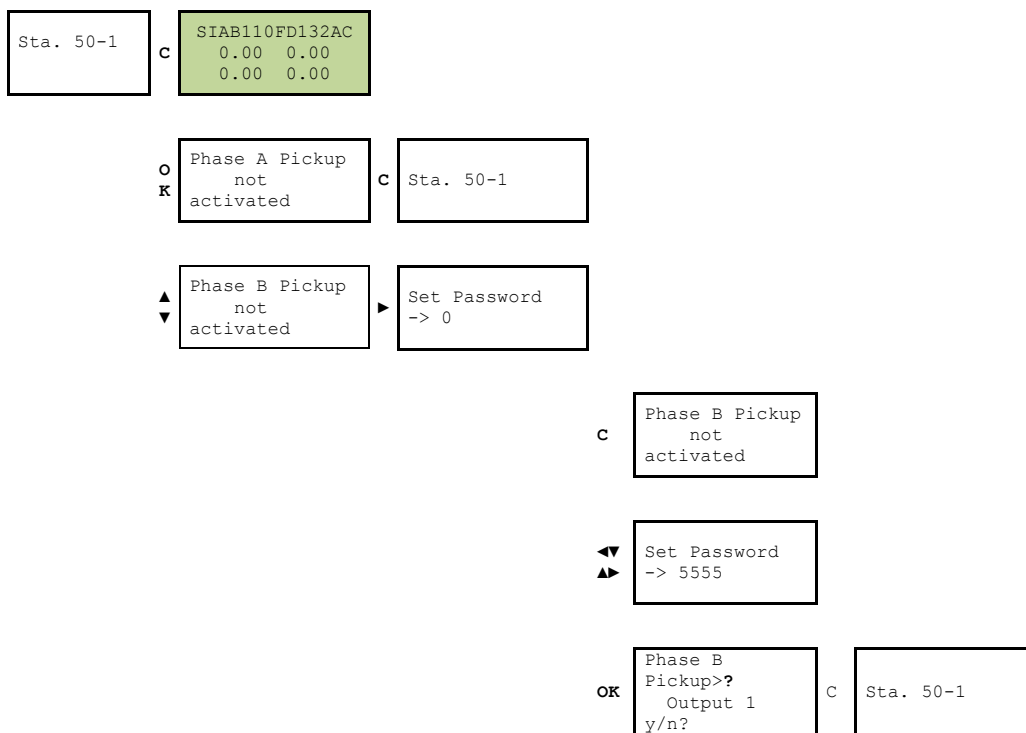

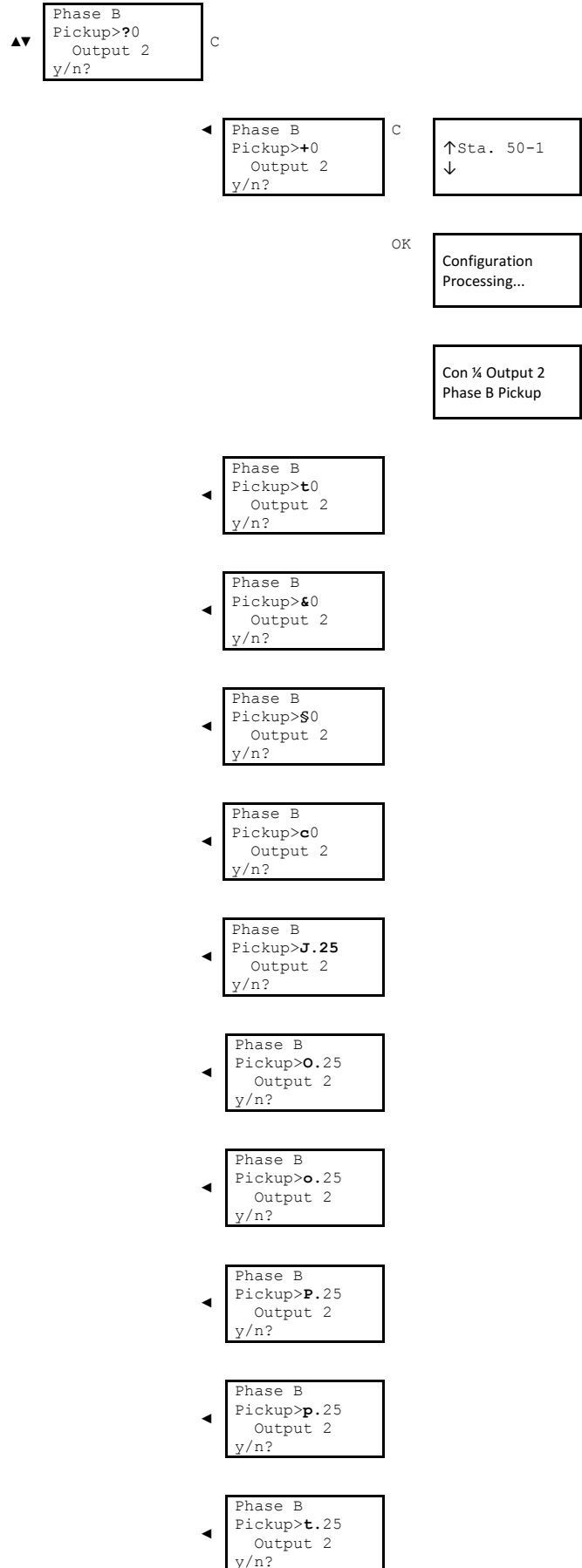

Phase B
Pickup>#
Output 2
y/n?

Phase B
Pickup>\$.25
Output 2
y/n?

Phase B
Pickup>Q.25
Output 2
y/n?

Phase B
Pickup>q.25
Output 2
y/n?

Phase B
Pickup>R.25
Output 2
y/n?

Phase B
Pickup>r.25
Output 2
y/n?

▲
▼ Phase B
Pickup>?0
Output 3
y/n?

▲
▼ Phase B
Pickup>?0
TripOutput
y/n?

► Phase B
Pickup>?0
52a y/n?

▲
▼ Phase B
Pickup>?0
52b y/n?

▲
▼ Phase B
Pickup>?0
Ext Trip
y/n?

▲
▼ Phase B
Pickup>?0
Blck. 50/51
y/n?

▲
▼ Phase B
Pickup>?0
Blck. 50/51G
y/n?

▲
▼ Phase B
Pickup>?0
SettingsG1
y/n?

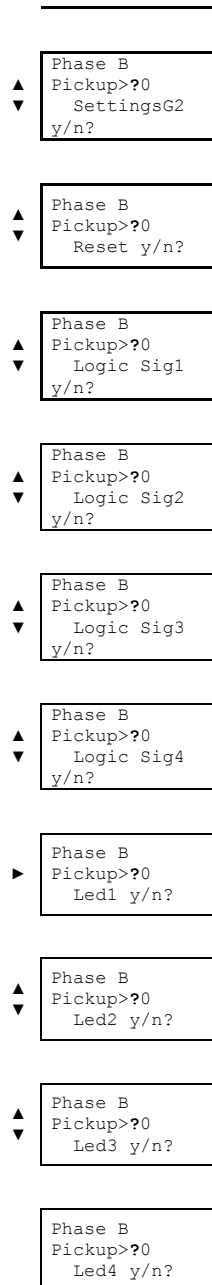

To view or remove the instantaneous states assigned to a physical output, logic or led, go to the "OUTPUT. LOGIC of LED STATE" menu.

Example for the output (but the same process should be followed to remove the configuration associated to a Logic Signal or LED):

Once the output current state (activated or deactivated) is displayed, press the "OK" key to check the configured signals. Use the "▲" and "▼" keys check all the signals that are configured in the specific output (up to 4). Hold the "RESET" key while viewing any of the signals associated with the output and it will be removed from the output configuration.

7 COMMISSIONING

7.1 Checklist for Commissioning

The commissioning sheets that are needed to register the commissioning process and the specific settings for each installed piece of relay are found in the Appendix.

7.2 Electrostatic discharge

Before handling any of the relay electronic components, make sure that you have read the section of the user manual related to electrostatic discharges.

7.3 Visual Inspection

Make sure that the cabling has been installed as per the external connection diagrams.

7.4 Earthing

It is very important for the relay to be earthed correctly. To check this, make sure that the relay earth connection, located on the reverse side of the relay, is correctly connected to the facility local earth connection.

7.5 Current transformers

The high voltage that is generated in the secondary circuits of current transformers can cause death and could damage the facility. Therefore, the secondary circuits of current transformers should never be opened.

7.6 Auxiliary power

The amount of auxiliary power required for the SIA-B relay should be checked: 230 Vac 50/60 Hz, 110 Vac 50/60Hz or 24 Vdc.

7.7 Front communications port

To perform this test, connect a PC with the SCom software program to the SIA-B relay, and check that there are no communication errors. It is important to check Communications port (COM) which is assign to USB.

7.8 Commissioning

It is recommended that the following safety measures are taken before starting up the facility for the first time, o rafter a trip event:

- MEVOCO recommends the use of the KITCOM accessory with a battery in the front port. This additional energy source allows the relay to be monitored and the trip to function without the need for self-power in any breakdown situation.
- Once all of the connections have been made, we recommend a check to make sure that they are correct, safe and well attached.
- The “complete test” menu procedure should be applied. **NOTE! See 6.13.**
- It is important to check that the measurements are correct once the facility has been powered up.

Maintenance: MEVOCO recommends a minimum of one facility inspection per year, to at least go through the test menu and check the values of the measurements.

8 APPENDIX

8.1 Identification

Date:.....
 Manager:
 Substation:.....
 Circuit:.....
 Model.....
 Serial no.....
 Software Versions:.....

8.2 Checks

Cabling check :

Box earth :

Vaux value :

8.3 Test menu

LEDs :	<input type="checkbox"/>	Output 3	<input type="checkbox"/>
Output 1 :	<input type="checkbox"/>	Trip Output	<input type="checkbox"/>
Output 2.	<input type="checkbox"/>		

8.4 Register of commissioning settings

Password :

Identification:

CT Ratio :

Phase CT Ratio:

Neutral CT Ratio :

50 1

Function Enable Yes No SHB

Tap..... x In

Time Delay : s

50G 1

Function Enable Yes No SHB

Tap..... x In

Time Delay: s

50/51

Function Enable Yes No SHB

Tap..... x In

IEC Curve type : Inverse Very Inverse Ext. Inverse LT Inverse

IEEE Curve type : Inverse Very Inverse Ext. Inverse Def. Time

Time Dial (TMS)

Time Delay s

50/51G

Function Enable Yes No SHB

Tap..... x In

IEC Curve type : Inverse Very Inverse Ext. Inverse LT Inverse

IEEE Curve type: Inverse Very Inverse Ext. Inverse Def. Time

Time Dial (TMS)

Time Delay.....s

SHB

Function Enable Yes No SHB

Tap..... %

Reset Time : s

Block Threshold..... xIn

52

Maximum number of openings

Maximum number of accumulated amperes

Maximum opening time.....

Maximum closing time

Time / openings number: Number of openings.....

Time period.....min

8.5 Inputs

- Input-1.
- Input-2.
- Input-3.

8.6 Outputs

- Output-1.
- Output-2.
- Output-3.
- Trip Output:

8.7 Leds

- Led -1.
- Led -2.
- Led -3.
- Led -4.

Ready
Neutral/Earth fault trip
Overcurrent trip
Thermal trip

8.8 Comments

.....

Person in charge of commissioning.....Date.....
 Maintenance performed on the..... by



Mevoco nv, Industrielaan 33A, 9800 Deinze, Belgium

+32 (0)9/380 30 49 • info@mevoco.be • www.mevoco.be

DW652121

©2021 Mevoco nv